



dinotec
Water & Pool Technology

PC DYNAMICS 4

private and professional

Instruction manual



CE

2010-534-63/1124/en

Simply enjoy the best water!

Notes:

dinotec GmbH
Water & Pool Technology
Philipp-Reis-Str. 28
61130 Nidderau/Germany
Tel.: +49(0)6187-413 79 -0
E-mail: mail@dinotec.de
Internet: www.dinotec.de

Subject to technical changes. Errors excepted.

Author: B. Dötsch

Date of manual: 04.11.2024. Valid for private and professional version, with Wi-Fi connection.

Table of contents

1	General Information	6
1.1	General	6
1.2	Notes in bold	6
1.3	Warranty	6
1.4	Electrical connection	7
1.5	Safety instructions	7
1.6	Transport damage	7
1.7	Consequential damage	7
1.8	Waste disposal	7
1.9	Remote maintenance	8
1.10	Regular control of water values	8
1.11	Further duties of the operator	8
1.12	Deviations in pH control measurements	8
2	Technical data and factory default settings	9
2.1	General	9
2.2	Chlorine control	9
2.3	Chlorine control for operation with chlorine gas - professional	10
2.4	Ozone – (professional model)	10
2.5	Chlorine dioxide – (professional model)	11
2.6	pH control	11
2.7	Poolcare control (measured)	12
2.8	Poolcare control (time-controlled)	12
2.9	Redox (ORP) control	12
2.10	Other	13
3	Description	16
3.1	The PCD4 is available in 2 model versions:	16
3.2	Selecting the disinfectant	17
4	Operation	19
4.1	Switching the device on or off	21
4.2	Display	22
4.3	Menu navigation	22
4.4	Changing the set value (example)	23
5	Menu structure – Explanations	25
5.1	Code	25
5.2	Device configuration - Code D	26
5.2.1	Time-controlled dosing of Poolcare	28
5.2.2	Display of redox measurement	28
5.2.3	Activating the filter control for PC DYNAMICS4 (private device model)	29
5.2.4	Chlorine gas controller (professional device model)	30
5.3	Calibration – Code B	33
5.3.1	Calibration chlorine	33
5.3.2	Calibration ozone	34
5.3.3	Calibration chlorine dioxide	34
5.3.4	Calibration Poolcare	34

5.3.5	Calibration pH	35
5.3.6	Calibrating the redox electrode	39
5.4	Setpoints	40
5.4.1	Setpoint settings for chlorine	40
5.4.2	Setting of disinfectant content (redox measurement)	41
5.4.3	Setpoint settings for Poolcare	41
5.4.4	Setpoint settings for pH	43
5.4.5	Control parameters (Code D)	43
5.4.6	Manual continuous dosing / Initial dosing (Code D)	45
5.4.7	Dosing time monitoring (Code C)	46
5.4.8	Switch-on delay	47
5.4.9	Sample water control (Code C)	47
5.4.10	Date and time	48
5.4.11	Automatic Electrode Cleaning AEC	48
5.5	Temperature compensation - Code C	50
5.6	Filter control	51
5.6.1	Filtration times	51
5.6.2	Flow monitor	52
5.6.3	Heating control	52
5.6.4	Solar	53
5.7	Relay settings - Code D	53
5.7.1	Controller type	54
5.8	Device data	56
5.9	Languages	56
5.10	Delete data memory / Factory settings	56
5.10.1	Analog outputs	57
6	dinoAccess App for remote access	59
6.1	Setup of remote access	59
6.2	Software update via dinoAccess	59
7	Maintenance and servicing	60
7.1	Cleaning and calibrating the electrodes	60
8	Alarm messages	61
8.1	List of error messages:	61
8.2	Resetting of alarms	63
8.3	Switch-off in case of an empty dosing container	63
8.4	External error dosing stop	63
8.5	Control limits	63
8.6	Trouble shooting	64
9	Spare parts and wearing parts	65
10	APPENDIX	66
10.1	What to do in case of a power failure	66
10.2	Battery	66
10.3	Adjusting the display contrast - Code C	66
10.4	Setting the bus address	67
10.5	Fuse	67
10.6	Liquid dosing agents for your PC DYNAMICS 4 system	68

11	Electrical connection/Terminal diagram – device model private	69
12	Electrical connection/Terminal diagram – professional device model	72
12.1.1	Connection actuator for chlorine gas	76
12.1.3	Terminal description potentiostatic measuring board	77
12.1.4	Terminal description analog output board	77
12.1.5	Connection of a diaphragm dosing pump via pulse frequency cable	78
12.1.6	Sample water monitoring via flow measurement	79

1 General Information

1.1 General

This manual contains instructions for the installation, commissioning, maintenance and repair of the PC DYNAMICS 4 systems.

The safety instructions and notes in bold type are to be observed at all times!

1.2 Notes in bold

In this technical information, the bold headings CAUTION, WARNING and NOTE have the following meaning:

Caution:

This heading is used if failure to observe the operating or working instructions, or prescribed procedures, or incorrect observation of such instructions and the like can lead to accident or personal injury.

Warning:

This heading is used if failure to observe the operating or working instructions or prescribed procedures, or incorrect observation of such instructions and the like can lead to damage to the equipment.

Note:

This heading is used to draw special attention to important points.

1.3 Warranty

The manufacturer guarantees the operational safety and reliability of the system only if the following conditions are observed:

- Installation, connection, setting, maintenance and repairs are carried out by authorized and qualified specialist personnel only.
- Only original replacement parts are used for repairs.
- The PC DYNAMICS 4 is used in accordance with the instructions given in this manual.

Warning:

The use of concentrated hydrochloric acid in the immediate vicinity of our equipment invalidates the guarantee.

Note:

Wearing parts are not covered by the warranty (see table chapter 10)

1.4 Electrical connection

Warning:

The PC DYNAMICS 4 may only be operated with 230 VAC and must be connected by an expert!

1.5 Safety instructions

The PC DYNAMICS 4 systems are manufactured and tested in accordance with DIN EN 61010-1/VDE 0411-1. The device left the factory in a safe condition. In order to maintain this condition and to ensure a continued safe operation, the user must observe the notes and warnings contained in this technical manual. If it must be assumed that a safe operation is no longer possible, the device must be turned off and taken out of service, and made safe against accidental operation.

This is the case:

- if the system shows visible evidence of damage,
- if the system is apparently no longer in working order,
- after longer periods of storage under unfavourable conditions.

1.6 Transport damage

The PC DYNAMICS systems are carefully packed by us for the purpose of transport. Please check that the delivery is complete and undamaged. Any transport damage **must** be notified **immediately** (carrier).

The system must never be exposed to temperatures outside a range of -20 to +70°C (transport and interim storage).

Subject to technical changes and modifications in the composition of components.

1.7 Consequential damage

We assume no responsibility for any liability losses or consequential damage while operating/using our products, because it is not possible for us to monitor a correct operation/use.

1.8 Waste disposal



In compliance with the Electrical and Electronic Equipment Act (ElektroG dated February 1st, 2007), waste electrical and electronic equipment (WEEE) must be disposed of separately from domestic waste in Germany, in order to facilitate recovery and recycling and to reduce the total amount of waste, thereby reducing the load on and number of waste disposal sites. When disposing of the device on hand, the corresponding local regulations are to be observed. Do not dump it in nature, instead bring it to a special collection point for waste electrical/electronic equipment and/or ask your specialist dealer to provide information when buying a new product.

1.9 Remote maintenance

Your system offers an option for remote maintenance. This feature means an increase in operational reliability. In addition, the costs for an on-site service that might be required otherwise can be saved. As is the case with all features of this kind, the possibility of remote access can also pose a safety risk for your network. We therefore generally recommend the use of a separate VPN router. We also recommend that you coordinate the setting up of the remote control for your individual situation as well as your specific safety requirements with your IT consultant.

dinotec does not take over any liability for possible damage caused by safety deficiencies. If a remote access has been set up, dinotec is authorized to access the system at any time for the purpose of debugging/troubleshooting, maintenance and monitoring.

1.10 Regular control of water values

The use of this system in the area of water treatment does not release you from your obligation to separately check the water values at regular intervals, preferably every week. You can check the values by means of a manual measuring device or a photometer. In this way, it can be ensured that any deviations from standard values are recognized immediately and can be removed.

1.11 Further duties of the operator

The operator is responsible for a proper use and operation of his swimming pool and the corresponding technology. The operator is also responsible that relevant standards, guidelines, regulations and legal duties to maintain safety in the area of the swimming pool and the plant room (e. g. child safety, floor drain in plant room, adequate ventilation and lighting in plant room, sufficient dimensioning of all working spaces, etc.) are complied with.

Moreover, we recommend an analysis of the filling water in advance to ensure that the system can be optimally adjusted to the water values in consultation with the trade partner. A regular visual inspection - preferably weekly - of the entire system is recommended.

1.12 Deviations in pH control measurements

Certain water conditions can result in deviations of the measured pH value when using different measuring methods, i.e. electronic meters and controllers and colorimetric or photometric measuring devices.

These deviations are dependent on the sample water and can be up to **0.4 pH**; they cannot be corrected.

Deviations of this kind are caused by so-called "salt errors in the colorimetric pH measurement". Certain types of salt contained in the water (enrichment due to evaporation) influence the reagent used for measurement (phenol red), which results in deviating measuring results. Electric measuring devices are not affected by this. In case of deviations, a different electric measuring device (calibrated with two calibration solutions) should be used for carrying out a comparative measurement.

The electric measurement will in any case produce a more precise pH value, provided the measuring, control and dosing unit has been properly calibrated.

2 Technical data and factory default settings

2.1 General

Description	Value
Power supply [V] at 50/60Hz	230 ± 10 %
Power consumption [VA]	10
Protection class:	IP 65
Fuse in device [mA]	400mA, fast-acting
Contact load relay [VA]	1000, max. 250V at 4A
Working temperature	0 - 50
Permissible storage temperature [° C]	-20 - +70
Permissible humidity [%]	90, non-condensing
Length of power cord [cm]	150
Dimensions of device (h x w x d) [mm]	264 x 234 x 90
Dimensions mounting plate (EASY or START pump) (w x h x d) [mm]	600 x 550 x 8
Dimensions mounting plate (DDE pump) (w x h x d) [mm]	600 x 7560 x 8
Dimensions cover (h x w x d) [mm]	610 x 560 x 170
Weight [kg]	1.8

Note:

The setpoints can be set only within the limits specified for alert values; the alert values can only be set within the limits of the alarm values.

2.2 Chlorine control

Item name	Adjustment ranges	FS ¹
Alarm value upper [mg/l]	0 - 4.0	0.80
Alert value upper [mg/l]	0 - 4.0	0.30
Set point chlorine [mg/l]	0 - 4.0	0.40
Alert value lower [mg/l]	0 - 4.0	0.10
Alarm value lower [mg/l]	0 - 4.0	0.05
Alarm delay [min]	0-15	2
P-band [mg/l]	0.0 - 4.0	0.1
Hysteresis [mg/l]	0	0 -1
Integral gain/Integral action time [sec]	0	0 - 1800
Derivative gain/Derivative action time	Fixed setting	
Manual continuous dosing [min]	0 - 60	0
Dosing time monitoring [min]	0 - 300	20

¹ FS: factory settings

2.3 Chlorine control for operation with chlorine gas - professional

Item name	Adjustment ranges	FS
Alarm value upper [mg/l]	0 - 4.0	1.0
Alert value upper [mg/l]	0 - 4.0	0.8
Set point chlorine [mg/l]	0 - 4.0	0.2
Alert value lower [mg/l]	0 - 4.0	0.1
Alarm delay [min]	0-15	2
Upper final value in case of feedback by potentiometer [Ω]	200-10000	1000
Lower final value in case of feedback by potentiometer [Ω]	0-199	0
Chlorine control type	Actuator with / without feedback	with feedback
Motor run time [sec]	1 – 120	12
Minimum pulse [sec]	1-10	5
P-band [mg/l]	0.0 - 4.0	0.1
Integral gain/Integral action time [sec]	0 - 1800	0
Derivative gain/Derivative action time	Fixed setting	
Hysteresis [mg/l]	0 - 1	0
Manual continuous dosing [min]	0 - 500	0
Dosing time monitoring [min]	0 - 300	20

2.4 Ozone – (professional model)

Item name	Adjustment ranges	FS
Alarm value upper [mg/l]	0 - 4.0	0.20
Alert value upper [mg/l]	0 - 4.0	0.15
Set point [mg/l]	0 - 4.0	0.05
Alert value lower [mg/l]	0 - 4.0	0.01
Alarm value lower [mg/l]	0 - 4.0	0.00
Alarm delay [sec]	0 – 15	2
P-band [mg/l]	0.1 – 0.4	0.1
Hysteresis [mg/l]	0 - 1	0
Integral gain/Integral action time [sec]	0 -1800	0
Manual continuous dosing [sec]	0 - 600	0
Dosing time monitoring [min]	0 - 300	20

2.5 Chlorine dioxide – (professional model)

Item name	Adjustment ranges	FS
Set point [mg/l]	0.00 – 4.00	0.1
Alarm value upper [mg/l]	0.00 – 4.00	0.4
Alert value upper [mV]	0.00 – 4.00	0.2
Alert value lower [mg/l]	0.00 – 4.00	0.05
Alarm value lower [mg/l]	0.00 – 4.00	0.01
Alarm delay [min]	0 - 15	2
P-band [mg/l]	0 - 500	0.1
Hysteresis [mg/l]	0 - 100	60
Integral action time		60
Derivative time	-	Fixed setting
Manual continuous dosing [min]	0 - 600	10
Dosing time monitoring [min]	0 - 300	20

2.6 pH control

Description	Adjustment ranges	FS
Alarm value upper [pH]	3.00 -12.00	8.0
Alert value upper [pH]	3.00 -12.00	7.55
Set point [pH]	3.00 -12.00	7.2
Alarm value lower [pH]	3.00 -12.00	6.8
Alert value lower	3.00 -12.00	6.4
Alarm delay [sec]	0 - 15	2
P-band [pH]	0.2 - 12.0pH	1.0
Integral gain / Integral action time [sec]	0-600	0
Derivative gain/Derivative action time	Fixed setting	
Deadband [pH]	0.0 - 1	0
Hysteresis [pH]	0-1	0.1
Manual continuous dosing [sec] ²	0-600 min.	4
Dosing time monitoring [min]	0 - 300	20

²Only for pH reduce, acts on relay 1

2.7 Poolcare control (measured)

Description	Adjustment ranges	FS
Alarm value upper [mg/l]	0 - 100	45
Alert value upper [mg/l]	0 - 100	40
Set point [mg/l]	0 - 100	30
Alert value lower [mg/l]	0 - 100	15
Alarm value lower [mg/l]	0 - 100	5
Alarm delay [min]	0 - 60	15
P-band [mg/l]	0 - 100	5
Integral gain / Derivative action time [sec]	0 - 1800	0
Derivative gain / Derivative action time [sec]	Fixed setting	
Manual continuous dosing [sec]	0 - 600	0
Dosing time monitoring [min]	0 - 300	20

2.8 Poolcare control (time-controlled)

Description	Adjustment ranges	FS
Pool volume [m ³]	1 - 150	50
Circulation time [h]	0 - 24	14
Pump capacity [l/h]	0 - 11	4.5
Concentration [%]	1 - 50	35
Precision dosing [%]	from -20 % to +20 %	0
Manual continuous dosing [l]	not adjustable	1.0
Duration continuous dosing [hrs]	not adjustable	12

2.9 Redox (ORP) control

Description	Adjustment ranges	FS
Setpoint [mV]	350-950	700
Alert value lower [mV]	350-950	650
Alarm value lower [mV]	350-950	550
Alarm delay [min]	0 - 60	2
P-band [mV]	0 - 500	30
Integral action time	not adjustable	0
Hysteresis [mV]	0 - 100	10
Manual continuous dosing [min]	0 - 60	6
Dosing time monitoring [min]	0 - 180	20

Note: In device versions intended for use with inline electrolysis, the system is supplied with chlorine electrodes (gold ring). Please observe the care instructions.

2.10 Other

Description	Adjustment ranges	FS
Device version	- Chlorine or Poolcare (measured) or Poolcare controlled and pH - Chlorine and redox and pH - Redox and pH	Poolcare measured and pH
Filter control ³	Yes/Non	Yes
Temperature control ³	Heating/heating and solar/none	Heating

Code

Description	Adjustment ranges	FS
Code	0; 11; NN; NN; 22	-

Setting the temperature compensation⁴

Item name	Adjustment ranges	FS
Temperature compensation	Manual/automatic	Automatic (PT 1000)
Temperature compensation [° C]	0 -50	25

Setting the filter times⁴

Description	Adjustment ranges	FS
Monday - Friday [h-min]	2 filter switch-on and 2 filter switch-off times 00:00 -23:59	On – Off 08:00 – 23:00 23:01 – 23:01
Saturday – Sunday [h-min]	2 filter switch-on and 2 filter switch-off times 00:00 -23:59	On – Off 07:00 – 23:00 23:01 – 23:01

³ Private model⁴ Private model

Setting the temperatures⁵

Temperature control heating, solar heating	Setting range	FS
Temperature control heating		
Alarm value upper [°C]	0 – 40	35
Alert value upper [°C]	0 – 40	30
Set point [°C]	0 – 40	27
Alert value lower [°C]	0 – 50	22
Alarm value lower [°C]	0 – 50	20
Alarm delay [min]	0 – 40	0
Solar heating		
Differential temperature [°C]	0 – 25	25
		30

Relay settings

Description	Adjustment ranges	FS
Relay 0	Filter control – Disinfection ⁶ – pH reduce ⁷ – pH raise ⁷ - Alarm ⁷ - Off ⁷	Filter control
Relay 1	Solar – Disinfection ⁷ – pH reduce ⁷ pH raise ⁷ – Alarm ⁷ – Off ⁷	Solar
Relay 2	Disinfection - pH raise - pH reduce - Alarm - Off	pH raise
Relay 3	Disinfection - pH raise - pH reduce - Alarm - Off	Common alarm
Controller type for all relays	Pulse frequency - Pulse-pause - On-Off	On-Off

Control mode

Controller	Adjustment ranges	FS
On-Off	On-Off	
Pulse frequency, if adjusted [pulses/h]	100 - 7200	7200
Period in case of pulse interval, if adjusted [sec]	1 - 99	10
Minimum pulse in case of pulse interval, if set [sec]	0.5 - 10	2

⁵ Private model

⁶ Only if no filter control was set

⁷ Only if no solar control (or no filter control) was set

Switch-on delay

Description	Adjustment ranges	FS
Switch-on delay [min]	0 - 90	5

Control ranges and resolutions

Measurement	Description	Adjustment ranges
Chlorine	Resolution measuring input [mV]	1
	Control range [mg/l]	0-4l
pH	Resolution measuring input [mV]	1
	Control range [pH]	3-9
Redox	Resolution measuring input [mV]	1
	Control range [mV]	50-950
Poolcare	Resolution measuring input [mV]	1
	Control range [mg/l]	0-100
	Control range [mg/l]	0-4

Sample water monitoring

Description	Adjustment ranges	FS
Sample water monitoring	Flow measurement/ Float switch	Float switch

Setting the sample water monitoring with flow meter

Description	Adjustment ranges	FS
Flow rate [pulses / l]	0 - 1000	410
Minimum flow [l/h]	10 - 49	40
Compensation	0.5 - 1	0.8

Analog interface

Description	Adjustment ranges	FS
Range adjustable [mA]	0 - 20 or 4 - 20	
Apparent ohmic resistance [Ω]	50	

3 Description

The PC DYNAMICS 4 is an easy to use instrument for measurement and control of the pH level.

Features:

-
- Measurement of disinfectant via flow measuring cell with sample water deficiency sensor or with accurate flow measurement via measuring cell universal fm
- In splashproof plastic housing
- Ready for connection 230V/50Hz
- Display of measured values via backlit graphic display
- Display and menu navigation in clear text
- Multilingual
- Operating status, warning and alarm messages are displayed in clear text
- Automatic electrode cleaning AEC
- BlueTooth® connection for smartphones

3.1 The PCD4 is available in 2 model versions:

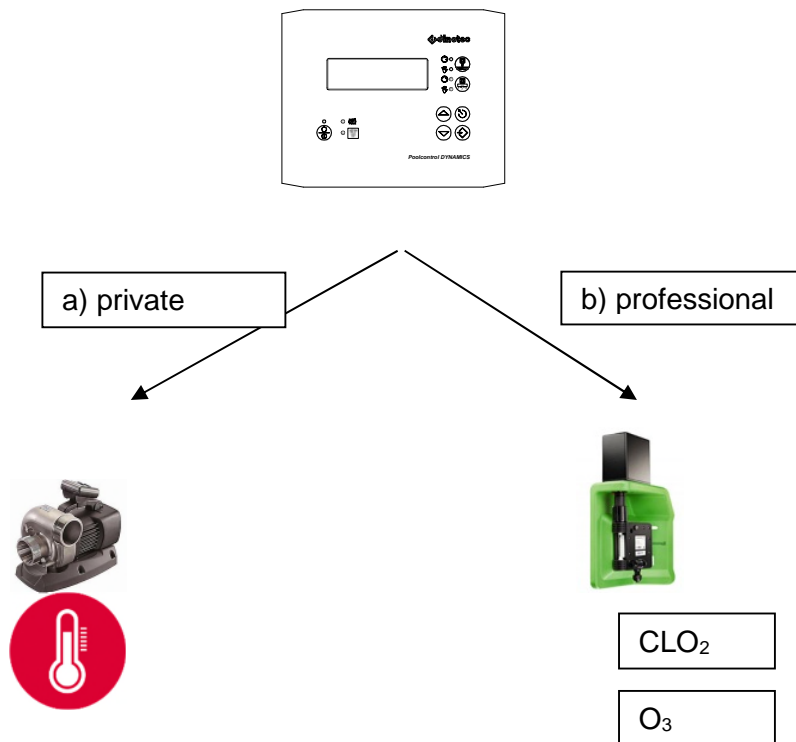

a) Private:

- Disinfection optionally for free or organic chlorine, via redox value, Poolcare (measured and time-controlled) and bromine, always in connection with pH, or only for pH
- Drive of a filter pump
- Temperature control for heating and solar system
- Ozone and chlorine dioxide are not measured.
- Heating and filter control can be used.
- In this model, output relays have fixed assignments, see chapter 11: Electrical connection/Terminal diagram

b) Professional:

- Disinfection optionally for free or organic chlorine (also with actuator for chlorine gas), ozone, chlorine dioxide, via redox value or Poolcare (measured and time-controlled), always in connection with pH, or only for pH
- Heating and filter control cannot be used.
- In this model, output relays have fixed assignments, see chapter:12 Electrical connection/Terminal diagram.

Note: To change the device type, go to “Device configuration – Code C”.

3.2 Selecting the disinfectant

The unit can be adjusted for the following disinfection methods:

a) Chlorine⁸

Measurement of disinfectant:	Free or organic chlorine + pH level + redox	Free or organic chlorine + pH level	Redox + pH level
Measuring electrodes:	Chlorine + pH + Redox	Chlorine + pH	Redox + pH

b) Chlorine-free

Measurement of disinfectant:	Poolcare measured ⁸ + pH value	Poolcare time-controlled + pH level
Measuring electrodes:	Chlorine + pH	pH

c) Bromine

Measurement of disinfectant:	Bromine + redox + pH level
Measuring electrode equipment:	pH

c) Ozone (professional model)

Measurement of disinfectant:	Ozone + redox+ pH level
Measuring electrode equipment:	Chlorine + redox + pH

d) Chlorine dioxide (professional model)

⁸ Only in connection with a potentiostatic measuring board.

Measurement of disinfectant:	Chlorine dioxide + redox + pH level
Measuring electrodes:	Chlorine + redox + pH

External dosing pumps are used for the dosing of disinfectants.

Professional model: chlorine gas control with control of a servomotor

All devices are equipped with a potentiostatic measuring electrode that can be used for measurement of both chlorine and Poolcare. This allows an easy switching between the disinfection methods.

Private model: The sample water temperature can be measured and displayed.⁹ This temperature can be used for compensation of the pH level.







The water temperature of the solar system can be measured and displayed.⁹

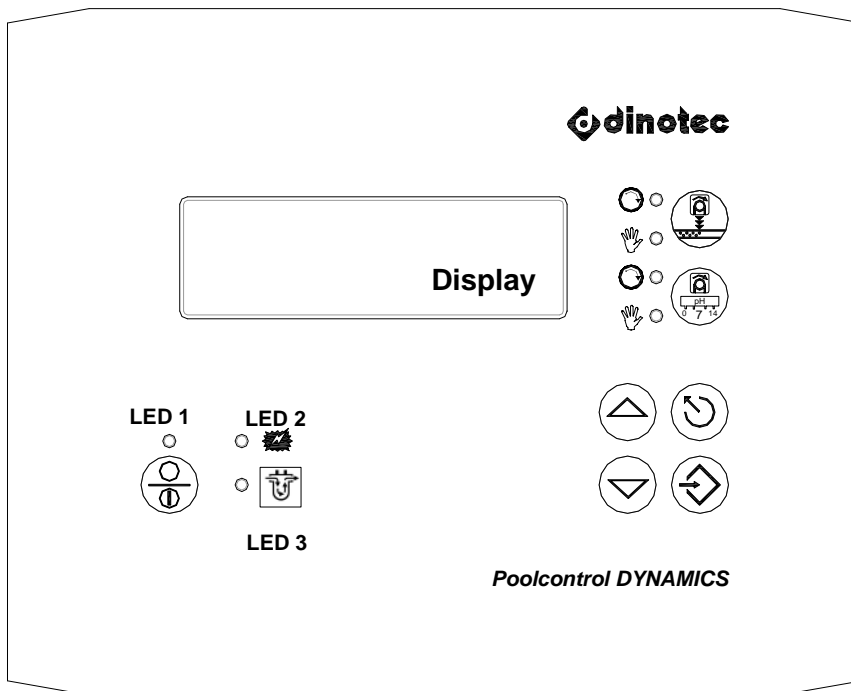





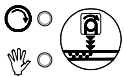

This means that a pool water heating can be implemented.

⁹ Temperature sensor PT-1000 is not included.

4 Operation

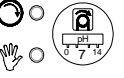









Button	Activity	Meaning
 	Menu / Alarms, scroll up	Scroll up in menu/alarm messages
	Changes values upward	Increase value within a range of values
	Menu / Alarms, scroll down	Scroll down in menu/alarm messages
	Changes values downward	Reduce value within a range of values
	Press the button briefly	The program jumps back to the next higher menu level
	Press the button for 5 sec. at least	Reset alarms and switch-on delay
	Select menu item	Displayed menu item ">" is selected
	Save	A setpoint is accepted and saved
	LED 2 (ret)	LED 2 flashes when an alarm is pending
	LED 3 (yellow)	On: sample water flow
		Flashes: sample water deficiency
		Off: external dosing stop pending

Button	Activity	Meaning
	Initial state	Control disinfection ON LED  off LED  on
		Dosing active LED  flashes
	Press the button for a longer time To return to the initial state: press the button again for a longer time	Control disinfection OFF LED  on
	Initial state	Control pH correction ON LED  off LED  on
		Dosing active LED  flashes
	Press the button for a longer time To return to the initial state: press the button again for a longer time	Control pH correction OFF LED  on



The function of button  is different, depending on whether a filter control has been configured in the PCD4 or not:

Function with configured filter control:

	LED 1 (green) lights  is displayed	The filter pump is switched on.
	LED 1 (green) is off	The filter pump is switched off, but starts automatically at the set filtration times.
	Press longer (min. 5 seconds):  is displayed Terminate by pressing for a longer time.	Allows a manual activation/deactivation of the filter pump, see below. Switches the filter pump off when the button is pressed within the set filtration times.
	If  is indicated in the display: Press briefly :  is displayed in addition when the filter pump is switched on.	Switches the filter pump on or off, independent of the set filtration times.

Function **without configured filter control:**

	LED 1 (green) is off	Button has no function.
---	----------------------	-------------------------

4.1 Switching the device on or off

The PCD4 is switched on as soon as the mains voltage is applied. The filter pump starts when the filter control has been configured and you are within the set filtration times. In this case, dosing will start after elapse of the switch-on delay.

The device can no longer be switched off via the button . If you need to deactivate the

device, press  **for a longer time** to switch the filter pump off (if configured). Then

switch the dosing functions off by pressing  and  **for a longer time** (LED  lights).

By pressing the buttons for a **longer** time, the filter pump and the dosing functions can be switched on again.

Note:

If you have configured the filter control, but the filter pump is not running (for example because you are outside the set filtration times), the dosing pumps will not be switched on (i.e. they remain switched off).

Note:

After a power failure and restoration of the current, the filter pump always switches to automatic mode and starts immediately at the set filtration times.

Note:

After a power failure and restoration of the current, the dosing always switches to automatic mode and will start immediately if necessary, even if they were switched off before the power failure (LED  lights).

4.2 Display

The following is displayed during operation:¹⁰

- Top left: measured free chlorine (0.56mg/l)
- Top right: measured redox voltage (700mV)
- Left center: measured pH level (7.22)
- Right center: measured water temperature¹¹, to the right is the solar temperature¹¹
- Bottom line: pending alarms and messages
- To the right of the measured values: current control variable in %
- The status of the AEC automatic electrode cleaning, if active

AEC			
Cl2:	0.56	mg / l	Redox: 700 mV
pH:	7.00	0% 0%	99 l/h
		28°C 78°C	
2+1 Alarm value chlorine			

Note:

There are alarm messages that are displayed for your information, also after the cause has been removed. These alarms must be acknowledged. To do this, press the  button for at least 5 seconds.

Note:

Depending on the device configuration, your screen display can vary slightly from the above image.

4.3 Menu navigation

You can access all settings via a menu.

This is similar to the user interfaces used in mobile phones, for example.

The process for setting values etc. is always the same. The following is an example to describe this process.

Screen display in the menu

- The maximum number of lines that can be displayed is 8. It is possible that there are additional entries in the menu below the current display.
-  indicates that there are submenus available in this menu.
- The current position is displayed with > on the left.
- Depending on the set code, different menu items are displayed.

In this manual, fields are highlighted in grey for clarity only. In the device itself, **no** display field is highlighted in any colour.

¹⁰ Examples for the versions chlorine with redox and pH measurement.

¹¹ Optional if a temperature sensor is connected

Cl2: 0.56 0% mg/l	Redox: 700 mV
pH: 7.00	55 l/h 23°C 78°C
2+1 Alarm value chlorine	

Display of pump capacity

The current control variable, which indicates the percentage of the pump power that is currently controlled, is displayed to the right of the measured values (in %). To illustrate this, it is circled in the following graphic.

Display of flow rates and temperature

In the middle of the right field, temperature and flow rates are displayed.

The temperature on the left is the temperature of the pool water (here: 23°C), the one on the right of the solar system (here: 78°C, if configured).

When using the universal fm measuring cell, the flow through the measuring cell (top line, above the temperature, here: 55 l/h) is displayed.

Other symbols

: Indicates that the filter pump is not in automatic mode.



: Indicates that the filter pump is switched on.



: Indicates that the heating or solar control is active.

4.4 Changing the set value (example)

If you want to change the set point for the control of pH:

Press the ENTER button ; the main menu is displayed.

```

-----Main menu-----
> Code: "C"
  ▶ Device configuration
  ▶ Calibration
  ▶ Setpoint settings
  ▶ Temperature compensation
  ▶ Relay settings
  ▶ Analog outputs
    
```

```

-----Main menu-----
Code: "C"
  ▶ Device configuration
  ▶ Calibration
  > ▶ Setpoint settings
  ▶ Temperature compensation
  ▶ Relay settings
  ▶ Analog outputs
    
```

Use or to select the desired menu item, for example: > Setpoint settings.



The current position is displayed with > on the left. Confirm the adjusted value

by pressing Eingabe /

ENTER:

The corresponding submenu is displayed:



Setpoint settings
▶ Chlorine
> ▶ pH values
▶ Switch-on delay 5 min.
▶ Sample water monitoring
▶ Date and time
▶ AEC
▶ Filter control

Use  or  to select the desired menu item, for example: pH.

Confirm with the  ENTER button.

The next submenu is displayed.



pH values
> ▶ Setpoints pH
▶ pH control
▶ Dosing settings

Use  or  to change the desired menu item, for example: pH.

Confirm with the  ENTER button.

The next submenu is displayed.

Setpoints pH
Alarm value upper 7.8 pH
Alert value upper 7.4 pH
> Set point pH 7.2 pH
Alert value lower 6.8 pH
Alarm value lower 6.4 pH
Alarm delay 2 min.



Use  or  to change the desired menu item, for example: the set point.

Confirm with the  ENTER button.

The value to be set starts flashing.



Value flashes

"Setpoints pH"
Alarm value upper 7.8 pH
Alert value upper 7.4 pH
> Set point pH 7.2 pH
Alert value lower 6.8 pH
Alarm value lower 6.6 pH

Use  or  to change the desired set value, for example to 7.1.

Confirm with the 

Eingabe / ENTER button.

After that, you can use  or  to adjust further values or you can quit the menu by pressing .

5 Menu structure – Explanations

Note:

This manual includes all available menu items. Remember that, depending on the selected code, not all menu items will be displayed, and/or not all menu items can be selected.

```
    ---Main menu---
> Code: "D"
  ▶ Device configuration
  ▶ Calibration
  ▶ Setpoint settings
  ▶ Temperature compensation
  ▶ Relay settings
  ▶ Analog outputs
  ▶ Device data
  Language:           English
  Factory settings: no
```

5.1 Code

There are 4 access levels that you can access by using codes. This is to protect the device from unauthorized operation.



- A) Code A - 00: All entries - except for code - are locked
- B) Code B - 11: End user code
- C) Code C – NN: Code for pool dealers/service staff
- D) Code D – NN: Code for dinotec factory service

5.2 Device configuration - Code D

As described in section 3.2, you can set 5 disinfection methods as well as filter control/solar control in the PC DYNAMICS 4. The selection can be made here:

---Main menu---	
Code: "D"	
>	▶ Device configuration
	▶ Calibration
	▶ Setpoint settings
	▶ Temperature compensation
	▶ Relay settings
	▶ Analog outputs
	▶ Device data
	▶ Language: English
	▶ Factory setting No

Device configuration	
>	PCD4 Professional
	Disinfection Free chlorine
	Redox measurement yes
	pH measurement: yes
	Filter control: yes
	temperature control Solar
	Communication Modbus
	Bus address: 1
	Contrast 40

Use  or  to select the desired configuration, here: Chlorine, pH, redox.
 Confirm with the ENTER  button.

Note:
The measurement and control of pH is always offered, independent of the selected disinfection method.



Disinfection:	Explanation
Poolcare	a) Measured: Poolcare is measured and controlled. Precondition is the use of a chlorine measuring electrode and an additional potentiostatic board. This selection allows the adjustment of setpoints, warning and alarm values for Poolcare.
	b) Time-controlled: Time-controlled addition of Poolcare in uniform (constant) partial quantities per day, depending on pool size and circulation times as well as the concentration of the used care agent. Explanation see below.
Redox	The appropriate chlorine value is adjusted via the measured redox value as auxiliary parameter value.
Free chlorine	Free chlorine is measured and controlled. This selection allows the adjustment of set point, alert and alarm values for free chlorine <ul style="list-style-type: none"> a) with motor-driven chlorine gas regulator (with and without feedback potentiometer, professional model) b) with dosing pump
Ozone (Model professional)	Ozone is measured and controlled. This selection allows the adjustment of set point, alert and alarm values for ozone
Chlorine dioxide (Model professional)	Chlorine dioxide is measured and controlled. This selection allows the adjustment of set point, alert and alarm values for chlorine dioxide.

5.2.1 Time-controlled dosing of Poolcare

The required quantity of Poolcare is calculated from the following information and is added over time:

- pool volume
- capacity of dosing pump
- daily circulation time
- concentration of used Poolcare product

The above data is set in the setpoints section for Poolcare.

Variable pause	10 sec.	Variable pause	10 sec.	///	Variable pause	10 sec.	Variable pause
				///			

Dosing Poolcare is switched on 

If you choose a time-controlled dosing of Poolcare, the setpoints, warning and alarm values for Poolcare cannot be set.

During each of the daily circulation times, at least one dosing is performed for 10 seconds. The dosing pump is always controlled with the maximum control variable (100%).

Note:

In case of a time-controlled dosing of Poolcare, the dosing monitoring is not active.

5.2.2 Display of redox measurement

"Device configuration"	
Disinfection	
pH raise or flocculation:	
>	Redox measurement yes

This menu is displayed for the device configuration "Free chlorine". You can decide at this point if you want to measure and display the redox value in addition. The redox value has no control function in this case.

5.2.3 Activating the filter control for PC DYNAMICS4 (private device model)

Settings	Explain text
Filter control	Yes: activates the filter control No: deactivates the filter control
Temperature control	Only possible with activated filter control. Solar: Adds the solar system for heating of the water. Heating: The water is only heated via the heat exchanger of the heating system.
Bus address	Sets the bus address of the PC DYNAMICS 4.
Contrast	Changes the contrast of the screen. Higher values result in a better readability when in daylight conditions.

Note:

You must check the relay assignment (see below) each time the filter control is activated/deactivated, since the assignment is changed in the process.

Go to the device configuration menu to set the filter control (and the heating control, if necessary) from "None" to "Heating".

Set your configuration in the menu item Temperature control to "Solar", if necessary.

To activate the filter control, open the housing of the PC DYNAMICS and change the relays as follows:

Relay 0 Filter control
Relay 1 Disinfection
Relay 2 pH reduce
Relay 3 Alarm

If you use the heating control (temperature control) in addition:

Relay 0 Filter control
Relay 1 Heating control (or solar, if selected)
Relay 2 Freely configurable, e.g. disinfection
Relay 3 Freely configurable, e.g. pH reduce

Go to the relay settings menu to re-assign the relay functions as described above.

5.2.4 Chlorine gas controller (professional device model)

The PC DYNAMICS 4 allows the use of dosing pumps, in-situ electrolysis systems and motor-driven chlorine gas controllers for the control of chlorine. This section describes the settings for the chlorine gas regulator.

```

---Main menu English---
Code                "11"
▶ Device configuration
▶ Calibration
> ▶ Setpoint settings
▶ Temperature compensation
▶ Relay settings
▶ Analog settings
    
```

```

Setpoint settings
> ▶ Chlorine--->>>
▶ pH values
Switch-on delay 5 min.
▶ Sample water monitoring
▶ Date and time
▶ AEC--->>>
    
```

```

Chlorine
▶ Setpoints chlorine
> ▶ Chlorine control--->>>
▶ Dosing settings
    
```

```

Chlorine control
> Controller type: Dosing
  pump
P-band                1.00 pH
Integral action time 0
sec.
Derivative action time fixed
Deadband              0.00 pH
Hysteresis            0.10 pH
    
```

Select the menu item "Chlorine_controller type: Dosing pump" and change it to "Actuator_with_potentiometer" or to "Actuator_without_potentiometer". This setting depends on whether the local chlorine gas controller has a potentiometer to indicate the position or not.

Measure the time that the motor of the chlorine gas regulator takes to travel from the position "closed" to the position "fully open".

This time is set for the parameter "motor run time":



```

Chlorine control
Controller type: Actuator
without
> Motor run time 12 sec.
Minimum pulse 5 sec.
P-band 0.10 pH
Integral action time 0 sec.
Derivative action time fixed
Hysteresis 0.10 pH
    
```

Warning:

In case of an actuator with feedback potentiometer, you need to adjust the PC Dynamics to the actual end positions of the actuator once (e.g. during initial commissioning).

**Setting of final values
Manual drive of chlorine gas regulator**

Press the  button for a second, the LED "Manual"  lights.

Select "Position detection". If the motor has a feedback potentiometer, you need to adjust the PCD to the actual end positions of chlorine gas regulator once using the settings that are displayed at this point.

Here you can also open and close the chlorine gas regulator manually.

Note:

You can only navigate to the selection field "Position detection" when you press the  button, and when the LED "Manual"  lights.

```



Chlorine control
> Position detection
Controller type: Actuator with
Motor run time 12 sec.

P-band 1.00 pH

Integral action time 0 sec.
Derivative action time fixed
Hysteresis 0.10 pH
    
```

```

> Positioning
Actual value actuator
      815 Ohm
Upper final value
      1000 Ohm
Lower final value
      0 Ohm
Open No
Close No
Stop No
    
```

Chlorine gas regulators	
Actual value actuator	The actual value of the actuator indicates the resistance value that is currently reported back by the actuator potentiometer.
Upper final value	Setting the upper final value: Go to the selection field "Open" and change the value to "Yes". The motor moves in the "Open" direction, until the upper final value has been reached and the actuator stops. Go back to "Upper final value" and press the save button  . (The set value remains constant even with active  button). When pressing  again, this value is applied to the upper final value.
Lower final value	Follow the same procedure as described above for the lower final value, with the only difference that the actuator will move in the direction "Close" (menu item "Close").
Open Close Stop	With the selection fields "Open" and "Close", the motor can be moved to the respective positions. The motor is stopped with the "Stop" feature. Choose "Yes" for this selection. Only one of the three check boxes can be activated at a time.

Information for chlorine gas regulator actuator without feedback potentiometer:

The positioning of the chlorine gas regulator is only relative, since there is no feedback. The controller recognizes that the chlorine level must be increased or decreased (correcting variable). It calculates the corresponding travel time of the actuator, taking into account the set motor run time. The direction the actuator moves depends in the direction of the desired change in the chlorine value (up or down).

Note:

The following table indicates which relay is to be switched during the various actions of the motor controller:

Activity	Relay 0	Relay 1
Open	energised	energised
Close	de-energised	de-energised
Stop	de-energised	energised

5.3 Calibration – Code B

A calibration of the electrodes is required when automatic and manual measurements differ greatly. It is also required during each new commissioning or re-commissioning. Code B must be set to be able to carry out a calibration.

Note:

Please observe the information about maintenance and servicing of the electrodes (instruction leaflet enclosed with the electrodes).

5.3.1 Calibration chlorine

The following description refers to the device configuration "Free chlorine". When the chlorine level is controlled via the redox level, the disinfectant content must be set by means of the setpoints (see section 5.4.2).

Note:

A calibration can only be carried out if there is a sufficient chlorine content in the process water. The content should be 0.1mg/l at least.

If there is no chlorine in the process water, set the value as follows:

- Start a manual continuous dosing, see section 5.4.6. Add chlorine until the desired content (e.g. 0.3 – 0.8mg/l free chlorine) has been reached. For previously non-chlorinated water, you will need approx. 30 - 40 ml of **dinochlorine liquid** per 10 m³ pool volume.

If the content of chlorine in the process water is sufficient, the above steps are not required.

The content is to be checked with a suitable measuring instrument (e.g. Pooltester or Photolyser). Once the required content has been checked and found to be constant over several measurements, the PC DYNAMICS 4 can be calibrated. Enter the measured chlorine level in "DPD value".

```

Calibration
> ▶ Calibration chlorine
  ▶ Calibration Poolcare
  ▶ Calibration pH
    
```

```

Calibration chlorine
> Measured value chlorine 0.40mg/l
  Slope                      25mV
  Input voltage               47mV
  DPD value                   0.40mg/l
  Calibration reset           No
    
```

This value is accepted after a short delay. The calibration of the chlorine electrode is complete. The slope of the electrode is calculated and displayed.

Note:

During the chlorine calibration, an entry of a DPD value below 0.10mg/l is ignored.

Note

When "Calibration not possible" is displayed, an automatic electrode cleaning (AEC) has been activated earlier. Please wait for the remaining time, which is displayed in the line above this one.

5.3.1.1 Electrode slope of chlorine electrode

The electrode slope indicates the voltage (in millivolt) released by the chlorine electrode per 0.1mg/l chlorine. A value of 25mV per 0.1mg of chlorine/l water is ideal. Under certain conditions (thermal water or dissolved minerals), the slope can be lower or higher. During operation, the slope of the electrode gradually changes. Please note that the slope will not be recalculated until the next calibration is carried out. If the lower (5mV) or upper limit value (50mV) is reached after the calibration, an error message is displayed.

When this error message is displayed, the chlorine electrode must be cleaned (and re-calibrated afterward) or renewed.

5.3.2 Calibration ozone

The ozone electrode is calibrated in the same way as for chlorine.

5.3.3 Calibration chlorine dioxide

The chlorine dioxide electrode is calibrated in the same way as for chlorine.

5.3.4 Calibration Poolcare

The following description refers to the device configuration "Poolcare".

Note:

A calibration can only be carried out if there is a sufficient content of Poolcare in the process water. The content should be 20mg/l at least.

If there is no Poolcare in the process water, set the value as follows:

- Start a manual continuous dosing (initial dosing), see section "5.4.6".
- Add Poolcare until the desired content (e.g. 20 – 30mg/l Poolcare) has been reached. If no Poolcare was used in the water before, you will need about 150-200ml **Poolcare oxa** per 10 m³ of water (given a concentration of 35%).

If the content of Poolcare in the process water is sufficient, the above steps are not required.

The content is to be checked with a suitable measuring instrument (e.g. Pooltester or Photolyser). Once the required content has been checked and found to be constant over several measurements, the PC DYNAMICS 4 can be calibrated.

Enter the measured chlorine level in "DPD value".

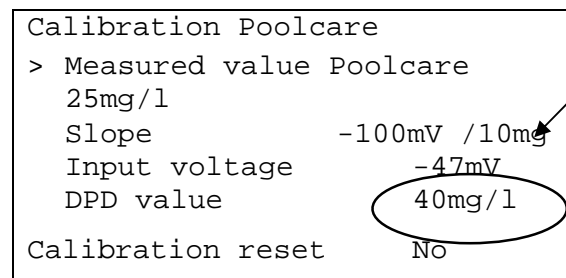
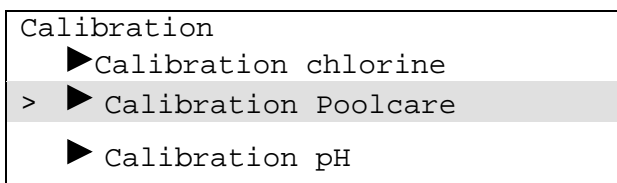

Note:

The input voltage is shown here with a negative prefix.

Note:

During the Poolcare calibration, an entry of a value below 10mg/l will be ignored.

Note

When "Calibration not possible" is displayed, an automatic electrode cleaning (AEC) has been activated earlier. Please wait for the remaining time, which is displayed in the line above this one.

With operating mode "Poolcare time-controlled", a DPD calibration for Poolcare is not required. It is, however, strongly recommended to carry out regular control measurements.

5.3.4.1 Electrode slope in case of Poolcare

The electrode slope indicates the voltage (in millivolt) released by the electrode per 10mg/l Poolcare. A value of -100mV/10mg/l is ideal. Under certain conditions (thermal water or dissolved minerals), the slope can be lower or higher. During operation, the slope of the electrode gradually changes. Please note that the slope will not be recalculated until the next calibration is carried out. If the lower (-20mV) or upper limit value (-200mV) is reached after the calibration, an error message is displayed.

When this error message is displayed, the potentiostatic electrode must be cleaned (and recalibrated afterward) or renewed.

5.3.5 Calibration pH

The calibration is selected via the menu "Calibration - Calibration pH".

Calibration	
▶	Calibration chlorine
▶	Calibration Poolcare
> ▶	Calibration pH

Calibration pH	
>	Type of calibration Two-point
Measured value pH	7.1 pH
Slope	58mV/pH
Zero point	0mV
Input voltage	7mV
Calibration pH 4/7	0.00 pH
Calibration reset	No

5.3.5.1 Setting the type of calibration - Code D

There are two ways to carry out a calibration:

1. The "two-point calibration" (by means of buffer solutions pH 4 and pH 7) - factory default setting
2. The "one-point calibration" (entry of a photometric value)

5.3.5.2 One-point calibration (photometric value)

With this type of calibration, the pH electrode is left in the measuring cell together with the attached measuring cable. Measure the pH level with a suitable test kit (e.g. Pooltester or Photolysers). The value determined is used for calibration of the PC DYNAMICS 4:

"Calibration pH"	
Type of calibration	One-point
Measured value pH	7.1 pH
Slope	58mV/pH
Zero point	0mV
Input voltage	7mV
> Photometer value	7.3 pH
Calibration reset	No

Navigate with the pointer to the line **Photometer value** and enter the measured value. Press the Enter button to complete the calibration. The zero point of the electrode is re-calculated and displayed. The setting for the slope is fixed at 58mV/pH.

Note:

The electrode slope is taken over as fixed value. A change in the electrode slope is not recorded in case of a one-point calibration. As a result, this type of calibration can lead to greater deviations in the measurement result.

If the voltages should be outside the above-stated ranges during the calibration process, or if a correct calibration is not possible for other reasons, a new line "Calibration reset" is displayed. Press the Enter button to switch to "Yes". In this way, the factory default settings are restored and you can start a new calibration.

Note:

If you select 'No', the incorrect calibration is accepted. However, the incorrect pH values and associated error messages will be displayed later during operation. Always try to find the cause of a failed calibration and then carry out another one.

5.3.5.3 Two-point calibration (by means of buffer solutions pH 4 and pH 7)

You need calibration solutions pH 4 and pH 7 with the red and green caps to carry out a 2-point calibration.

Process with flow measuring cell:

1. Close the ball valves for sample water.
2. Unscrew the measuring electrode from the measuring cell, the measuring cable is left in the electrode (the connection rotates simultaneously).
3. Dry the pH electrode with a soft paper towel before calibrating it, or clean it with an electrode cleaner (0181-184-01) first, if required.
4. Open the menu item **Calibration**.

"Calibration pH"	
Type of calibration	Two-point
Measured value pH	7.1 pH
Slope	58mV/pH
Zero point	0mV
Input voltage	7mV
> Calibration pH 4/7	7.0 pH
Calibration reset	No

5. Place the electrode in buffer solution pH 7.0. The displayed "**Measured value pH**" should fluctuate around 7 pH. Bring the pointer > to the line "**Calibration pH4/pH7**". The value in this line must jump to 7.0 pH. When the display indicates that this value has stabilized (after about 1-2 minutes), press the Enter (save) button to confirm.
6. Dry the pH electrode with a soft paper towel. Place the electrode in buffer solution pH 4.0. The displayed value should fluctuate around 4 pH. The value in the line "**Calibration pH4/pH7**" must jump to 4 pH and must remain stable. Once you have pressed the Enter button to confirm, the calibration of the pH electrode is complete.
7. Screw the electrode back into the measuring cell.
8. Re-open the ball valves for sample water.

Process in case of measuring cell universal fm

Different from the flow valve, the pH electrode remains installed in the universal fm measuring cell during the calibration.

1. Close the ball valves for sample water.
2. Place a suitable receptacle with a minimum volume of half a liter (500 ccm) under the yellow drain hose below the measuring chamber.
3. Open the sampling valve below the measuring chamber (turn the handle 90 degrees down).
4. When the measuring cell is empty, unscrew the measuring chamber by turning it counterclockwise (turn to the left).
5. Dry the pH electrode with a soft paper towel before calibrating it, or clean it with an electrode cleaner (0181-184-01) first, if required.
6. Open the menu item **Calibration**.

"Calibration pH"	
Type of calibration	Two-point
Measured value pH	7.1 pH
Slope	58mV/pH
Zero point	0mV
Input voltage	7mV
> Calibration pH 4/7	7.0 pH
Calibration reset	No

7. Hold buffer solution pH 7.0 below the electrode. The displayed **"Measured value pH"** should fluctuate around 7 pH. Bring the pointer > to the line **"Calibration pH4/pH7"**. The value in this line must jump to 7.0 pH. When the display indicates that this value has stabilized (after about 1-2 minutes), press the Enter (save) button to confirm.
8. Dry the pH electrode with a soft paper towel. Hold buffer solution pH 4.0 below the electrode. The displayed value should fluctuate around 4 pH. The value in the line **"Calibration pH4/pH7"** must jump to 4 pH and must remain stable. Once you have pressed the Enter button to confirm, the calibration of the pH electrode is complete.
9. Flush the inside of the measuring chamber with clean water.
10. Screw the measuring chamber in by turning it clockwise (turn to the right). Tighten only hand-tight.
11. Re-close the sampling valve below the measuring chamber (turn the handle 90 degrees up to a horizontal position).
12. Re-open the ball valves for sample water and check the measuring cell including sampling valve for any leaks.

After each calibration, the electrode slope and the zero point deviation are recalculated and displayed.

Warning:

Before immersing the pH electrode in the buffer solutions, flush the electrode with water and dry it with a soft paper towel.

Note:

The calibration process is not complete when the voltage of the pH electrode is outside of the following ranges in case of a 2-point calibration:

-58mV and + 58mV for pH=7
and
+116mV and +232mV for pH=4

If the voltages should be outside the above-stated ranges during the calibration process, or if a correct calibration is not possible for other reasons, a new line "Calibration reset" is displayed. Place the arrow > on this line and use the arrow buttons to switch to "Yes". In this way, the factory default settings for the pH electrode are reset and you can start a new calibration.

Note:

If you select 'No', the incorrect calibration is accepted. However, the incorrect pH values and associated error messages will be displayed later during operation. Always try to find the cause of a failed calibration and then carry out another one.

5.3.5.4 Interrogating the slope/zero point of the pH electrode

It is possible to query data about slope and zero-point deviation of the pH electrode. The query is made via the menu navigation.

The displayed zero point should be within a range of **0mV ± 58mV**.

5.3.5.5 Explanation pH electrode slope

The electrode slope indicates the voltage (in millivolt) released by the pH electrode per pH. A value of about 58mV/pH is ideal. A new pH electrode can release a maximum of 58.2mV/pH. During operation, the slope of the electrode gradually changes. Please note that the slope will not be recalculated until the next calibration is carried out. As soon the slope falls below 50mV/pH, the electrode should not be used any longer.

5.3.5.6 Explanation pH electrode zero point

Physically, the zero point of a new pH electrode is 7.00pH. This corresponds to a measuring voltage output of 0mV. Due to temperature influences etc. this value can be slightly different (max. 0.10 pH). During operation, the zero point can go up or down. Please note that the slope will not be recalculated until the next calibration is carried out. If the deviation (from 7.00 pH) exceeds 1 pH (= +/- 58mV), the pH electrode should not be used any longer.

5.3.5.7 Interrogating the input voltage of the pH electrode

The current input voltage of the pH electrode can be displayed for testing purposes.

5.3.6 Calibrating the redox electrode

Since the PCD 4 uses a redox electrode without a reference system, no calibration is required.

The correct functioning of the redox electrode can be checked by means of 475 mV calibration solution via the display for the input voltage.

5.4 Setpoints

In this menu you can enter the desired setpoints for chlorine, redox, Poolcare, pH, filter control and solar system.

You can also adjust the control parameters and the dosing settings here.

The automatic electrode cleaning AEC is set in this menu.

For explanations, see section 5.4.5.

The setpoints can be set with Code B = 11.

```

---Main menu English---
Code                "11"
▶ Device configuration
▶ Calibration
> ▶ Setpoint settings
▶ Temperature compensation
▶ Relay settings
▶ Analog outputs
    
```

```

Setpoint settings
> ▶ Chlorine--->>>
▶ pH values
Switch-on delay5 min
▶ Sample water monitoring
▶ Date and time
▶ AEC
▶ Filter control
    
```

5.4.1 Setpoint settings for chlorine

```

Chlorine
> Setpoints chlorine ---
>>>
▶ Chlorine control
▶ Dosing settings
    
```

```

Setpoints chlorine
Alarm value upper      1.00mg/l
Alert value upper      0.70mg/l
Set point              0.40mg/l
Alert value lower      0.20mg/l
Alarm value lower      0.10mg/l
Alarm delay            2 min.
    
```

Set the desired value, e.g. 0.5 mg/l.

You can enter both upper and lower alert and alarm values. If the measured value exceeds or falls short of the alert and alarm values, this is indicated in the bottom status line.

Note:

Setpoints can be set only within the limits specified for alert values; alert values can only be set within the limits of the alarm values.

There is a correlation: Alarm value lower < Alert value lower < Setpoint < Alert value upper < Alarm value upper.

It is possible to set a separate alarm delay for each controller in the setpoints setting.

This prevents that a short overshoot of measured values triggers an alarm and that dosing units are switched off as a result.

An alarm is only triggered and the corresponding dosing functions switched off if an error has been pending over the entire alarm delay time.

5.4.2 Setting of disinfectant content (redox measurement)

The following description refers to the device configuration "Redox/pH".

When the level of free chlorine is measured and controlled with a chlorine electrode, you must adjust the disinfectant content by means of the DPD method (see section 5.3.1).

The redox potential (ORP) is a so-called auxiliary parameter value, which, being a measure of the germ-killing speed, is used as a control value for the chlorine content. In general, the higher the redox value, the better the disinfection of the water.

The system is set to a redox setpoint of 700mV at the works.

Experience has shown that, when using this value, the controller will set an appropriate chlorine level of 0.3-0.5mg of chlorine/l.

You should check the chlorine content regularly (preferably every two weeks) with a suitable measuring instrument (e.g. Pooltester or Photolyser). If it is too high, adjust the redox setpoint to a lower value, for example to 625mV. If, on the other side, the chlorine content is too low, increase the redox set point.

Redox	
> Set point	625mV
Alert value lower	650mV
Alarm value lower	600mV

The **bromine content** is set in the same way.

Note:

Since there is no linear relation between the redox value and the chlorine/bromine content, it is possible that chlorine levels will differ even when the redox value is the same, for example after a backwash is carried out or fresh water is added. This is not a malfunction of the PC DYNAMICS 4.

5.4.3 Setpoint settings for Poolcare

When setting the Poolcare setpoints, a distinction is made between: measured and controlled dosing of Poolcare, and time-controlled.

5.4.3.1 Poolcare dosing measured and controlled

The descriptions and parameters given for chlorine in section 5.4.1 apply also in this case. The explanations about controller values also apply accordingly.

5.4.3.2 Poolcare dosing time-controlled

Dosing is made dependent on time using constant quantities every day. The following setting parameters allow you to adjust the amount of Poolcare to fit your conditions:

Poolcare time-controlled	
> Pool volume	50 m ³
Circulation time	12 h
Pump capacity	4.50 l/h
Concentration	35
Precision dosing	0 %

Poolcare time-controlled	Explanation
Pool volume	You can adjust your pool size here.
Circulation time	The required amount of Poolcare is added over the runtime of your pump. To do this, set your circulation time for one day. If necessary, read about your filter control settings for information about this.
Pump capacity	The capacity (liters/hour) of your Poolcare dosing pump is entered here. Correct this value after changing the pump hose size or after changing the capacity manually on the pump itself.
Concentration	The concentration of the used Poolcare product is required to adjust the dosing time in such a way that the desired Poolcare content in the pool is reached.
Precision dosing:	<p>The precision dosing feature is used for adapting to external influences.</p> <p>In case of an outdoor pool, for example, less Poolcare is required when the weather is cloudy; when it is sunny, a higher quantity of Poolcare is required. The dosing should also be increased when several bathers use the pool at the same time.</p> <div style="text-align: center;">  </div> <div style="display: flex; justify-content: space-around; align-items: center;"> <div style="text-align: center;"> <p>-20%</p> <p>Low load</p> <p>(e.g. in bad weather)</p> </div> <div style="text-align: center;"> <p>0</p> <p>Normal load</p> </div> <div style="text-align: center;"> <p>+20%</p> <p>High load</p> <p>(e.g. in case of sunshine)</p> </div> </div>

If the precision dosing is set to 0, it can be assumed that a maintenance dosage of about 0.5l Poolcare (concentration 35%) per 10 cubic meters of the pool size is required per week.

Note:

Dosing is always carried with 100% power control of the pump. The continuous dosing time monitoring is disabled in the "Poolcare time-controlled" mode. It is possible that the Poolcare pump will only be activated after a certain time (up to 30 minutes).

5.4.4 Setpoint settings for pH

Follow the instructions for the setpoint settings for chlorine in section 5.4.1 to adjust the setpoints for pH. The explanations about controller values also apply accordingly.

5.4.5 Control parameters (Code D)

You can adjust the setpoints for control and dosing parameters separately for each controller (chlorine, Poolcare, redox and pH),
The following example is for a pH controller:

```

---Main menu English---
Code                      "D"
▶ Device configuration
▶ Calibration
> ▶ Setpoint settings
▶ Temperature compensation
▶ Relay settings
▶ Analog outputs
    
```

```

Setpoint settings
> ▶ Chlorine
  ▶ pH values--->>>
  Switch-on delay 5 min.
  ▶ Sample water monitoring
  ▶                               Date
  and time
    
```

```

pH values
▶ Setpoints pH
> ▶ pH control
  ▶ Dosing settings
    
```

```

pH Control
> P-band, pH           1.00
  Hysteresis, pH      0.10
  Integral action time,
  sec.                 0
  Deadband, pH        0.00
    
```

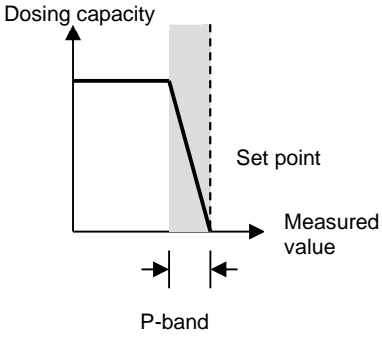
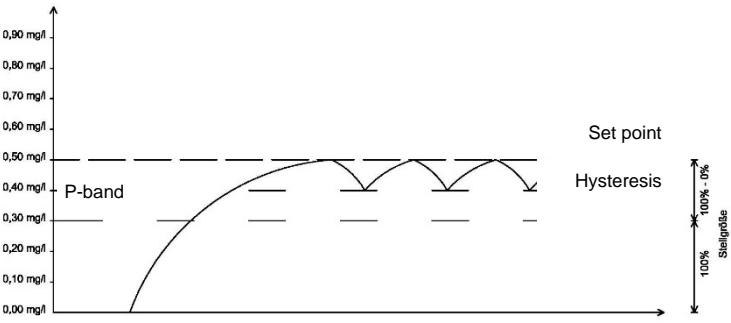
Control parameter	Explanation
<p>P-band</p>	<p>A virtual control range is defined around the setpoint, the so-called P-band (proportional band). If the measured value is outside this P-band, dosing is carried out with 100% of the dosing capacity. If the measured value exceeds the P-band, the dosing capacity is reduced in line with the P-band until the dosing stops altogether on reaching the setpoint.</p> 
<p>Hysteresis</p>	<p>An adjustable range around the setpoint. When the setpoint has been reached, the controller stops dosing. It is only after running the hysteresis loop (downward) that the controller will restart dosing.</p> 
<p>Integral action time</p>	<p>The integral gain of the PID-control.</p>
<p>Deadband</p>	<p>Adjustable range around the set point with no dosing. Is required when two pH pumps are used (raise and reduce) or for chlorine gas controllers. This prevents a fast and continuous switching between the activation of both pumps or the controller.</p>

5.4.6 Manual continuous dosing / Initial dosing (Code D)

You can adjust the duration of manual continuous dosing separately for each controller (chlorine, Poolcare, redox and pH) in the **Setpoints** settings.

The following example is for a pH controller:

```

---Main menu English---
Code                    "11"
▶ Device configuration
▶ Calibration
> ▶ Setpoint settings
▶ Temperature compensation
▶ Relay settings
▶ Analog settings
    
```

```

Setpoint settings
▶ Chlorine/Poolcare
> ▶ pH values
Switch-on delay 5 min.
▶ Sample water monitoring
▶ Date and time
▶ AEC--->>>
    
```

```

pH value
▶ Setpoints pH
▶ pH control
> ▶ Dosing settings
    
```

```

Dosing settings
> Man. contin. dosing, min.
  5
Dosing time monitoring,
min. 20
    
```

Manual continuous dosing allows you to quickly add water treatment chemicals to the process water, e.g. during commissioning.

Set the desired time and confirm by pressing  . The dosing starts immediately.

You can interrupt the continuous dosing by setting the time to 0. Confirm by pressing  .

Note:

For safety reasons, the time is reset to 0 in the menu after elapse of the continuous dosing time or after an interruption. This means that each time you want to carry out a (new) continuous dosing, you have to set the time again.

Depending on your settings, the pumps work with the maximum power control. After the manual continuous dosing time is over, the pumps are switched off and the system changes to the dosing mode. The dosing time monitoring is ignored for the duration of the continuous dosing.

Continuous dosing in case of "Poolcare - time-controlled"

When the PC DYNAMICS 4 is set to operating mode "Poolcare (time-controlled)", the fixed preset dosing quantity is 1l/10m³.

After expiry of the manual continuous dosing, the system changes to the maintenance dosing mode according to your settings (pool volume - circulation time - precision dosing). No further settings are necessary.

Note:

Please ensure that the filter system will run for at least 12 hours after a manual continuous dosing.

If the power to the unit is interrupted, continuous manual dosing is stopped.

Note:

With continuous manual dosing, only the dosing pump for pH reduce (relay 1) is started.

5.4.7 Dosing time monitoring (Code C)

You can adjust the dosing time monitoring separately for each controller (chlorine, Poolcare, redox and pH) in the **Setpoints** settings.

The following example is for a pH controller:

```

pH value
  ▶ Setpoints pH
  ▶ pH control
> ▶ Dosing settings
    
```

```

"Dosing settings"
> Man. contin. dosing 5 min
  Dosing time monitoring
    20 min
    
```

If the dosing function should not reach 100% of the dosing capacity within the time entered for the P-band or the set point, it is assumed that there could be an error (broken hose etc.). For safety reasons, the dosing function is switched off in this case. If the dosing time

monitoring should have responded, check the reason and confirm by pressing the  button for 5 seconds.

The dosing time monitoring is deactivated when set to "0".

Attention:

The dosing time monitoring is a safety function. The correct setting of the dosing time monitoring depends on the individual pool situation and should be carried out by a specialist. A setting for the dosing time monitoring that is too long can lead to overdosing and damage to the pool.

Attention:

By pressing the reset button (5 sec), the dosing time monitoring is reset and re-starts. This can lead to overdosing and damage to the pool.

Attention:

If no dosing time monitoring is set (0 min), overdosing and damage to the pool may occur.

5.4.8 Switch-on delay

Setpoint settings
▶ Chlorine
▶ Redox
▶ pH values
> Switch-on delay 5 min.
▶ Sample water monitoring
▶ Date and time
▶ AEC

After any interruption in the operation (e.g. initial commissioning, backwashing or activation of the circulation), it normally takes some time until representative sample water is available. In order to prevent a resulting overdosing, a switch-on delay time should be set. In this case, the dosing functions will only start when the switch-on delay has elapsed.

Note:

This setting applies globally to all controls.



The switch-on delay can be cancelled by pressing the ESC key for 5 seconds. It is reactivated the next time the device is switched on (power is restored).

5.4.9 Sample water control (Code C)

Setpoint settings
▶ Chlorine
▶ pH
Switch-on delay 5 min.
> ▶ Sample water monitoring
▶ Date and time
▶ AEC

Sample water monitoring
Flow measurement method
> Flow l/h 0,0
Flow rate, P/l 50
Min. flow, l/h 15
Compensation 0.80

The sample water monitoring can be carried out both via the flow cell using a float switch (normally open), or via measuring cell fm using an impeller meter.

Flow monitoring	Explanation
Flow measurement method	To switch between float switch and flow measurement with impeller meter.
Flow 0.0 l/h	Actual flow (actual value)
Flow rate - - - p/l	Sensor constant - may only be changed in consultation with dinotec GmbH.
Minimum flow	When the flow rate falls below the value set here, "Sample water deficiency" is displayed; the dosing functions are deactivated.
Compensation	Change this value only in consultation with dinotec!

For measuring systems

- redox & pH
- Poolcare (time-controlled) & pH as well as
- pH as individual system,

a float switch is used for sample water monitoring. If not done before, please change the "Flow measuring method" to "Float switch".

5.4.10 Date and time

You can set the date and time for the real time clock in the **Setpoints** settings. This is especially necessary if you want to use the filter control or automate the process of the automatic electrode cleaning (AEC).

Note:

You must switch from summer to winter time manually.

A leap day on 29th February is inserted automatically.

5.4.11 Automatic Electrode Cleaning AEC

The automatic electrode cleaning is a process that triggers an automatic electrochemical cleaning of the potentiostatic electrode. The cleaning time is determined via the menu. The self-cleaning cycle itself takes 10 seconds. The measured value is frozen for 5 minutes so that the electrode can re-polarize. The cleaning can be carried out up to 2 times per day. A distinction between the days of the week cannot be made.

In the top middle of the main screen, "AEC" is displayed when AEC is enabled.

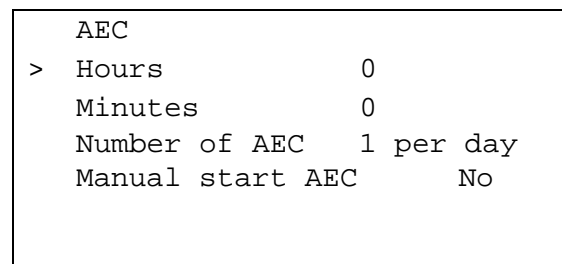
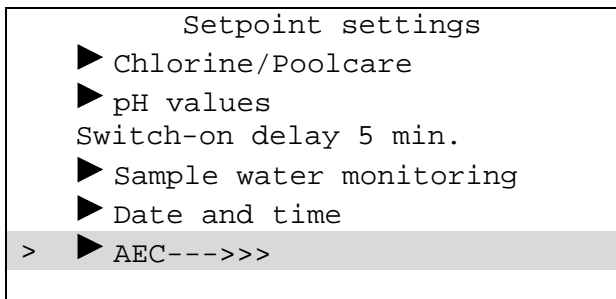

AEC	
Hours Minutes	e.g. 11 35 AEC is carried out at 11: 35. Precondition: The time was set before.
Number of AEC	0: No AEC 1: Is carried out at the set time, in this example at 11:35 2: Is carried out at the set time, and 12 hours later , in this example at 11:35 and 23:35
AEC manual start	Yes: AEC is carried out immediately

Note:

After an AEC has been carried out, the addition of disinfectant is deactivated for 5 minutes.

Note:

The potentiostatic electrode is checked after an AEC. If this check is not successful, a message "Check pot. probe" will be displayed; the control remains active. Repeat the AEC in this case. Check the measuring cable or replace the electrode, if required.

Note:

After the AEC has been carried out, no calibration for chlorine (Poolcare) can be carried out for the next 15 minutes.

The following screen is displayed during calibration:

Calibration chlorine	
Measured value chlorine	0.40mg/l
Slope	25mV
Input voltage	47mV
Calibration reset	No
AEC complete in	14 min
Cannot calibrate	

Note

After loading the factory settings (reset), the time for execution of an AEC is reset to "0 hours 0 minutes" and the number to "1 per day".

5.5 Temperature compensation - Code C

Physically, pH measurements shift under the influence of temperature. Specifications for new electrodes are usually given for 18 °C. For this reason, a default setting of 28°C is set for temperature compensation in the basic settings of the PC DYNAMICS 4. When using a temperature sensor PT1000, the measured temperature can be used (setting "automatic"). The pH measuring values are adjusted in accordance with the appropriate factors in this case.

Please select whether the temperature is compensated to a fixed value (manually, in this example 29°C) or to the measured value (automatic).

```

---Main menu English---
Code                "C"
▶ Device configuration
▶ Calibration
▶ Setpoints setting
> ▶ Temperature compensation
▶ Relay settings
▶ Analog outputs
Language:           English
    
```

```

Temperature compensation
> Compensation      Manual
Manual compensation  28° C
    
```

A temperature sensor type PT1000 must be connected for measurement and display of the water temperature.

Note:

The display does no longer indicate whether the temperature compensation is automatically or manually set to a temperature.

5.6 Filter control

5.6.1 Filtration times

If the filter control has been selected in the device configuration, there is an option for further settings here.

```

---Main menu---
Code                "C"
▶ Device configuration
▶ Calibration
> ▶ Setpoints setting
▶ Temperature compensation
▶ Relay settings
▶ Relay settings
▶ Analog outputs
Language:           English
    
```

```

Setpoint settings
▶ Chlorine/Poolcare
▶ pH values
Switch-on delay 5 min.
▶ Sample water monitoring
▶ Date and time
▶ AEC--->>>
> ▶ Filter control
    
```

```

Filter control
> ▶ Filtration times
▶ Flow monitor
▶ Temperature control
▶ Solar
    
```

Setting the filter times

```

Filtration times
> ▶ Monday
▶ Tuesday
▶ Wednesday
▶ Thursday
▶ Friday
▶ Saturday
▶ Sunday
    
```





Select the desired days.

The filtration times are set for each day (example: Tuesday).

There are two time intervals available:

Monday	On	Off
>	8:00	12:00
	17:00	22:00
Filtration times		OK!
Accept from previous day		Yes

You have two filter time intervals per day. In the above example, the filter pump will run on Tuesdays from 8:00 to 12:00 and from 17:00 to 22:00.

Move the cursor > to the lines where you want to change the filter times. Select the time to be changed with . Change the time using  or  and confirm with . The next value to the right of it flashes, which means it can be set.

Set the times so that the time for the first filter interval (upper line) is before the second interval. The switch-on time must always be before the switch-off time.

If this is not the case, **"Times incorrect"** will be displayed in the filter times line after you quit the settings with . If the times are correct, **OK!** will be displayed. If you only want to set one time interval, set the first two times to 00:00 (on) and 00:00 (off) and set your times in the second line. The filter pump will not start at 00:00.

If you want the filter to run at the same times every day, set your filter times for Sunday and then select **Accept from previous day** for the remaining days (one after another).

5.6.2 Flow monitor

You can connect a flow monitor to the PCD 4, which monitors the circulation and, if it fails, switches off the filter pump, heating and dosing units. You can set the alarm delay here. (Explanation see chapter "Setpoints".)

Note:

If the flow monitor has responded, the message "External dosing stop" is displayed.

5.6.3 Heating control

Temperature control	
Alarm value upper °C	35
Alert value upper °C	30
Setpoint °C	25
Alert value lower °C	20
Alarm value lower °C	10
Alarm delay, min.	2

The heating switches whenever the pool water temperature has been below the setpoint for one minute. If the measured temperature has been above the setpoint for a minute, the heating switches off again.

5.6.4 Solar

```
Solar
  Differential temperature °C 5
```

The solar control can be selected via the configuration menu. If the heat measured by solar temperature sensor allows this, the pool is heated by the solar system. The heating is switched off in this case.

When this happens, adjustments are made via the differential temperature. This means: to switch to the solar system, the solar temperature around the differential temperature must be higher than the water temperature.

Example:

- The water temperature is 28°C.
- The set temperature is 30°C; as a result, the heating is generally switched on.
- The differential temperature is 5°C.
- The system will switch to the solar system when the temperature in the solar sensor exceeds 32°C (28 + 5).
- The solar system is switched off again when the solar temperature sensor measures a temperature below 32°C (the heating takes over).

5.7 Relay settings - Code D

Each output relay can virtually be freely selected in case of the PC DYNAMICS 4. Depending on the application, you decide which dosing pump or alarm output to connect to which relay. If the operation is configured for filter pump/solar system, the filter pump always uses relay 0 and the control valve of the solar system uses relay 1.

```
---Main menu English---
Code                    "C"
▶ Device configuration
▶ Calibration
▶ Setpoints setting
▶ Temperature compensation
> ▶ Relay settings
▶ Analog outputs
Language:                English
```

```
Relay settings
> Rel0 Filter control
  Rel1 Solar
  Rel2 pH raise
  Rel3 Alarm
```

Filter control	If 'Filter control' has been selected in the configuration, relay 0 is automatically assigned to this function. This is where you connect the filter pump (or contactor). If no filter control has been selected in the configuration, relay 0 can be assigned as required.
Heating	If 'Heating' has been selected in the configuration, relay 1 is automatically assigned to this function. This is where you connect a valve (actuator) for the heating control. If no filter control has been selected in the configuration, relay 1 can be assigned as required.
Solar	If 'Solar' has been selected in the configuration, relay 1 is automatically assigned to this function. This is where you connect a valve (actuator) for the solar control. If no solar control has been selected in the configuration (and no heating), relay 1 can be assigned as required.
Disinfection	The relay controls a dosing pump. This pump can deliver the appropriate chemicals for disinfection (chlorine/Poolcare).
pH reduce	The relay controls a dosing pump. This pump can deliver the appropriate chemicals for reducing the pH level.
pH raise	The relay controls a dosing pump. This pump can deliver the appropriate chemicals for raising the pH level.
Flocculation	The relay turns a pump on, which can be used for adding flocculant to the process water. This pump is always running when the dosing function of the PC DYNAMICS 4 is enabled. In case of a pH level alarm or a water deficiency, this relay turns off.
Off	The relay has not been assigned to any controller and is not required.
Alarm	The relay switches a potential-free contact (normally open) when an alarm is pending after the alarm delay time is over. This can be used, for example, to transfer the alarm to a facility management system or an alarm horn, etc.

Note:

If, for example, filter control or heating/solar has been configured, relay 0 and relay 1 are permanently assigned (fixed) with these values. In this case, only relay 2 and 3 are feely assignable.

Note:

You must check the relay assignment every time the filter control is activated/deactivated, since the assignment is changed during these processes.

5.7.1 Controller type

In the menu "Relay settings", you can adjust each controller separately for different controller types. This allows the operation of different pumps and dosing equipment with the PC DYNAMICS 4. The following screen shows an example of the options for the disinfectant control. The settings apply accordingly for all controls and the alarm relay.

Disinfection relay
> Controller type ON-OFF
Pulse frequency 7000 p/h
Duration of period 10 sec.
Minimum pulse 2 sec.

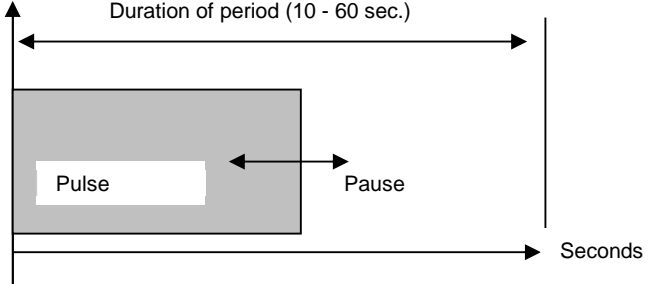
Controller type	
ON / OFF controller	When reaching the defined setpoint, the dosing system is turned off; when falling below the setpoint, the dosing system is turned on. Used, for example, in electrolysis systems or contactors, which are switched via the set point. A hysteresis value must be entered in this case.
Pulse frequency	This controller type can be used, for example, for control of diaphragm dosing pumps, model dinodos DDE (frequency control). The controller delivers a certain number of pulses per hour for this purpose. In our example, the setting is 7000 pulses/h. As the dosing requirements decrease, the number of pulses is reduced.
Pulse + Pause	<p>The dosing rate of the connected pump is the result of a linear relation of pulse length (pulse) - pause (pulse interval relation) of the switching state at the relay. The period length is defined as the time between the closing operations; the pulse length as the time during which the contact remains closed.</p> <p>The minimum pulse length is 0.5 seconds (minimum pulse), the maximum is 60 seconds.</p> <p>As the dosing requirements decrease, the length of pulses is reduced, the pauses get longer.</p> 

Note:

In case of an On/Off controller, the P-band is not evaluated. The set hysteresis, on the other hand, affects the switching behaviour.

Note:

If you want to control an IN-situ electrolysis system (salt electrolysis) or a bromine feeder for disinfection, select the On/Off controller and set the chlorine setpoints in the controller settings for the P-band to 0.

Note:

The relay that is used for the alarm output should be set to controller type "On-off".

5.8 Device data

"Device data"		
>	Device number	1234
	Software version	0111
	Date of manufacture	0111
	▶ Manufacturer	

In this menu you will find all important data about your device. It also includes the contact data for the dinotec service hotline. Please have the device data ready when you need to contact the service hotline.

5.9 Languages

At present (February 2017) the following languages are available:

- German
- English
- French
- Dutch
- Spanish
- Polish
- Ukrainian
- Russian
- Italian
- Czech
- Hungarian
- Romanian
- Croatian
- Serbian

Further languages will be implemented.

5.10 Delete data memory / Factory settings

---Main menu---		
▶	Calibration	
▶	Setpoint settings	
▶	Temperature compensation	
▶	Relay settings	
▶	Device data	
	Language: English	
>	Factory settings:	yes

With this menu item, you can restore the factory settings (reset).

Set the value for "**F**actory **s**ettings" to "yes". Confirm by pressing the ENTER button. The device will restart.

Note:

The calibrations for free chlorine, pH and Poolcare and setpoints, warning and alarm values are restored after a reset.

All other values are retained.

5.10.1 Analog outputs

The PCD 4 allows the output of all measuring values as unit current signals 0 [4]-20mA to DIN IEC 60381-1. You can adjust the type of output here.

An analog output board 0133-103-00 is required for this.

The following figure explains this:

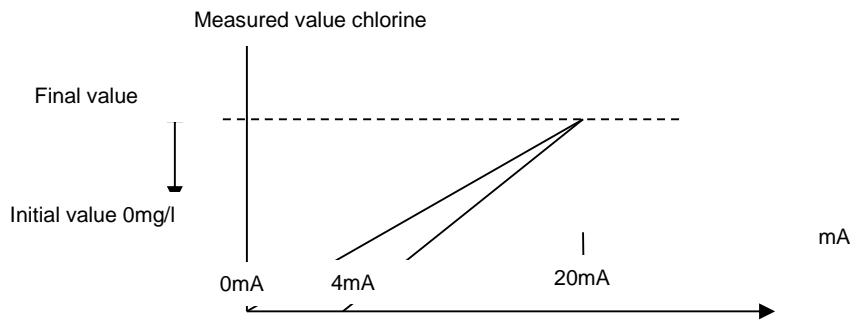

It is assumed in this case that the measuring output is for chlorine. When the parameters as described below are set correctly, the result is the following:

If the PC DYNAMICS measures 0mg free chlorine per liter, there are 0mA applied at the analog output.

If the measured value is 1.0mg chlorine per liter, there are 20mA applied at the analog output. Appropriate intermediate values are output in a linear way, for example 10mA at 0.5mg chlorine/l.

The corresponding start and final values are arbitrary, e.g. between 0-4mg chlorine/l.

Connections to a RS-485 interface, Modbus and the dinoWin software are therefore possible.

```

---Main menu English---
Code                "11"
▶ Device configuration
▶ Calibration
▶ Setpoint settings
▶ Temperature compensation
▶ Relay settings
> ▶ Analog outputs
    
```

```

Analog outputs
▶ Output 1 Disinfection
> ▶ Output 2 pH
▶ Output 3 temperature
▶ Output 2 redox
    
```

Output 1	Disinfection, mg/l
> Type	0-20mA
Output	Disinfection mg/l
0(4)mA	0.00
20mA	1.00

Set value	Explanation
Type	Here you select whether the analog output range will be between 0 - 20mA or 4-20mA. If the setting is 4-20mA, circuit interruptions can be recognized (industry standard).
Out	Here you can assign the desired controller to the previously selected analog output (in the above example, disinfection is assigned to output 1).
0 (4)mA	This is the lower limit value. Assign the chlorine value to this limit value for output of the analog output 0 or 4mA (in this example, 0mg/liter).
20mA	This is the upper limit value. Assign the chlorine value to this limit value for output of the analog output 20mA (in this example, 1mg/liter).

The evaluation of a falling characteristic curve has not been implemented at present.

6 dinoAccess App for remote access

6.1 Setup of remote access

Requirements:

- Apple iPhone from iOS9
(<https://apps.apple.com/de/app/dinoaccess/id1474266309>)
or
- Android smartphone
(<https://play.google.com/store/apps/details?id=de.dinotec.dinoaccess&hl=de>)
from Android 6.0 (Marshmallow)

Download the **dinoAccess** app from the Apple AppStore or Google PlayStore.

1. Open the app
2. Create an account
3. Add PC DYNAMICS (yellow "+" symbol)
4. Enter an individual device name and a device location -> Next
5. Enter Wi-Fi access data -> Next
6. Got to the Wi-Fi settings of the smartphone and select the new device (starts with PC DYNAMICS). Go back to dinoAccess.
7. The device connects automatically. After a successful connection, the app switches to the overview screen.

The dinoAccess app is used for remote display of hygiene parameters on smartphones. This is particularly useful if the PC DYNAMICS 4 is installed in places that are difficult to access. The display of the PC DYNAMICS 4 with the current measured and displayed values is shown on the smartphone.

6.2 Software update via dinoAccess

You can download the latest software version to your device via dinoAccess. The set point settings must be checked after an update.

To download an update to your device, open the dinoAccess app. You must be connected to the device. Go to "Settings" and press "Check for update". Confirm that you want the update to be carried out.

7 Maintenance and servicing

The housing may only be wiped with a damp cloth; the use of sharp, caustic or abrasive cleaning agents (acid cleaners, lyes, etc.) is not permitted! Stubborn stains can be removed with a rinsing agent or plastic cleaner, which must be tested on an invisible spot (inside) first. The PC DYNAMICS 4 is easy to maintain, but should be checked and maintained at regular intervals by a skilled technician.

Please observe the following information on maintenance and servicing of the PC DYNAMICS 4 as well as the separate manuals, e.g. for dosing pumps, chlorine gas regulator and electrodes.

The device does not include any components that can be repaired or replaced by the user. It is not necessary for this reason to unscrew any parts, open the device or disassemble it. Our experience has shown that many reasons for complaint can be solved in the course of a telephone conversation.

If you have any problems with your device, please contact the dinotec service hotline first. This will save you time and possibly trouble. Our service hotline staff will be happy to explain our warranty policy and repair processing in detail to you, and how to proceed in case you need to return your device.

If you have any further questions regarding our measuring, control and dosing system, please contact your dinotec pool dealer or our service department.

7.1 Cleaning and calibrating the electrodes

Depending on the water quality, the electrodes are to be cleaned every 4 to 5 weeks (or more frequently, if required, e.g. in case of strongly ferrous water or salt deposits in case of brine). The pH electrode must be recalibrated. Check the electrodes for any mechanical damage (e.g. breakage of glass) and wipe them dry with a soft paper towel. If there is scaling on the electrode surface, the electrodes are to be immersed in a special liquid electrode cleaner (0181-184-01) for about 1 minute and then rinsed thoroughly with water.

- If the metal pin of the redox or chlorine electrode shows a brown coating, clean the metal ring with cleaning paste (0181-184-00) and then rinse it with clear water. Afterwards, dry the pH electrode with a soft paper towel. A calibration is not required in this case.
 - The redox electrode is wear-free, provided there is no mechanical damage.
 - The service life of pH and chlorine electrodes depends to a high degree on operating conditions and maintenance. The normal service life is between 1 and 2 years.
- Both pH and chlorine electrodes are wearing parts.

Warning:

Before removing the electrodes, switch off the dosing and close the sample water inlet and outlet at the sampling points.

Note:

Deposits on the diaphragm of the pH electrode can lead to malfunction (pH value jumps). In this case the electrode is to be cleaned with a liquid electrode cleaner.

Warning:

Other acids or cleaning agents can destroy the electrodes.

To keep your PC DYNAMICS performing at its best in the long term, you should have it serviced once a year by your specialist partner. This will ensure optimum water quality and efficient water treatment. The sticker on your unit reminds you to carry out maintenance. You can download your user manual using the integrated QR code.

8 Alarm messages

8.1 List of error messages

Alarm message	Cause	Activity	Remedy	Display type/Alarm relay
Electrode slope pH	Electrode slope < -50mV	Controller function remains active, faulty calibration value is accepted	Recalibrate or replace the electrode	Message on display Alarm LED flashes
Electrode slope chlorine	Electrode slope < -10mV or > 50mV	Controller function remains active, faulty calibration value is accepted	Recalibrate or replace the electrode	Message on display Alarm LED flashes
Error zero point pH	Zero-point shift > ±58mV	Controller function remains active, faulty calibration value is accepted	Recalibrate or replace the electrode	Message on display Alarm LED flashes Alarm relay closes
Upper alarm value chlorine		Dosing chlorine is deactivated		Message on display Alarm LED flashes Alarm relay closes
Lower alarm value chlorine				Message on display Alarm LED flashes Alarm relay closes
Upper alarm value Poolcare		Dosing Poolcare is deactivated		Message on display Alarm LED flashes Alarm relay closes
Lower alarm value Poolcare				Message on display Alarm LED flashes Alarm relay closes
Lower alarm value redox				Message on display Alarm LED flashes Alarm relay closes
Upper alarm value pH		Dosing pH raise is deactivated		Message on display Alarm LED flashes Alarm relay closes
Lower alarm value pH		Dosing pH reduce and chlorine is deactivated		Message on display Alarm LED flashes Alarm relay closes
Sample water deficiency		All dosing functions are deactivated	Ensure sample water supply	Message on display Sample water LED flashes
Empty signal chlorine	Empty signal for chlorine container enabled	Dosing chlorine is deactivated	Replace chlorine container	Message on display Alarm LED flashes Alarm relay closes

Alarm message	Cause	Activity	Remedy	Display type/Alarm relay
Empty signal pH reduce	Empty signal for canister pH minus enabled	Dosing pH reduce and chlorine is deactivated	Renew pH-Minus container	Message on display Alarm LED flashes Alarm relay closes
Empty signal pH raise	Empty signal for canister pH plus enabled	Dosing pH raise is deactivated	Renew pH-Plus container	Message on display Alarm LED flashes Alarm relay closes
Dosing time monitoring xxx	Exceeding the set permissible dosing time	Dosing concerned is turned off	Confirm	Message on display Alarm LED flashes Alarm relay closes
Dosing time monitoring pH raise ; no pH increaser/dosing pump connected		Dosing concerned is turned off	Set to off via Device configuration - pH raise or flocculation ; see section	Message on display Alarm LED flashes Alarm relay closes
Control limit disinfection exceeded	Redox: >950mV	Dosing concerned is turned off	Reduce Redox value	Message on display Alarm LED flashes Alarm relay closes
Control limit disinfection fallen short of	Redox: < 50mV	Dosing concerned is turned off	Increase redox value	Message on display Alarm LED flashes Alarm relay closes
Control limit pH exceeded	pH: > 12	All dosing functions are deactivated	Reduce pH value	Message on display Alarm LED flashes Alarm relay closes
Control limit pH fallen short of	pH: < 3	All dosing functions are deactivated	Increase pH value	Message on display Alarm LED flashes Alarm relay closes
Check pot. electrode	Autom. electrode test after cleaning failed	None - control remains active	Manually restart AEC Check measuring cable Replace probe	Message on display Alarm LED flashes
----	----	System not dosing	Submenu has been selected, press  to change to the main menu	
External error dosing stop	The flow monitor in the recirculation line has responded	System not dosing and filter pump disconnects		Message on display Alarm LED flashes Alarm relay closes

Note:

Use the button  to have the alarm messages displayed one after another if there are several alarm messages pending.

8.2 Resetting of alarms

There are alarm messages that are displayed for your information, also after the cause has been removed. These alarms must be acknowledged. To do this, press the  button for at least 5 seconds.

Each time this button is pressed, all current alarms are reset, provided the particular error has been removed/corrected.

8.3 Switch-off in case of an empty dosing container

When a dosing container is empty, the dosing function concerned is deactivated¹². If the dosing of pH is deactivated as a result, the dosing of disinfectant will be adjusted automatically as well. Conversely, the dosing of pH remains active if the disinfectant is missing. The alarm relay is activated; the alarm is reset automatically after the fault is removed.

8.4 External error dosing stop

For example, a flow monitor can be connected to terminal 25-26. If this contact is closed, the entire filter and heating control and the dosing are switched off. The message "External dosing stop" is displayed.

In case of the setpoint values for the filter control, a separate alarm delay time is provided for this switch-off under 'Flow monitor'.

8.5 Control limits

The dosing for redox and pH is only enabled when the measured values are within specific limits. If this is not the case, a malfunction of the electrode or measuring input is assumed and there is no dosing carried out.

If one of the values is outside this limit, a corresponding error message is displayed in the bottom line of the display.

Limits:	Redox:	50 - 950mV
	pH:	3 - 12



Note:

If the actual value is outside these limits during commissioning, the value must be adjusted first by adding chemicals until it is within the required range.

For information about the procedure, refer to section 5.4.6

¹² When using suitable suction lances.

8.6 Trouble shooting

Defects	Error cause / Remedy	Solution
Screen is dark after turning on/LED above the power button is off	No power	Check house fuse/earth leakage circuit breaker Insert the mains plug correctly
	Micro fuse blown	Check and replace 400mA slow blow, 230V
Incorrect date and time after a power failure	Back-up battery empty	Replace the CR 2032, following this set date and time
Dosing pumps for disinfectant do not start	AEC was activated	Wait for 5 minutes
	Switch-on delay enabled	Wait or press  for a longer time.
	Filter control was configured: - You are outside the set filter times - Filter pump was switched off manually (symbol  in display)	Start the filter pump manually or wait.
	Sample water deficiency	Remove cause
Calibration of disinfection is not possible	AEC was activated	Wait for 15 minutes
	Container 'correction pH' is empty	Refill
	Control limit exceeded	See above
When checking the chlorine/Poolcare measuring input with a pH-T tester, the displayed value differs from the expected result	Display output is compensated	Switch to "float switch" for the duration of the sample water monitoring,

AI Inside. Supported by artificial intelligence

Your PC DYNAMICS features an “AI-Inside” sticker with a QR code (starting in 2025). Scanning the QR code takes you to Dino, the dinotec chatbot that provides useful help when needed. This chatbot, based on artificial intelligence, will competently answer any questions you may have about your PC DYNAMICS.



9 Spare parts and wearing parts

See assembly instructions.

10 APPENDIX

10.1 What to do in case of a power failure

In case of a power failure, the device maintains the last operating condition. Once the power has been restored, the device continues to work with the previous settings.

10.2 Battery

The PC DYNAMICS 4 has a battery to ensure the internal clock keeps running when no voltage is applied. This battery should be replaced after one to two years (lithium, type Cr 2032).

Fig. 10.2-1: View on the cover (inside)

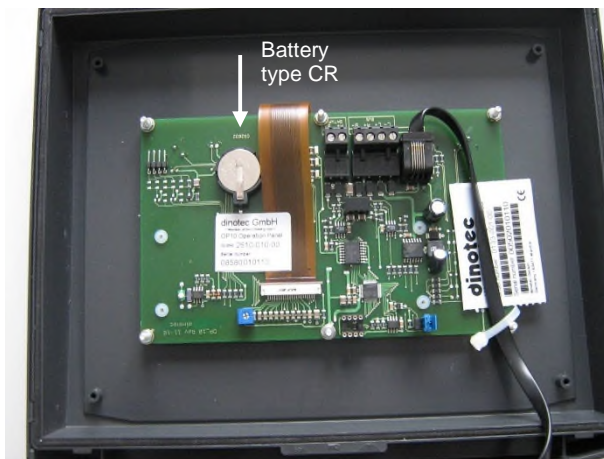

10.3 Adjusting the display contrast - Code C

The device has a setting for the contrast of the display. In some circumstances this setting can be used to improve the readability at the installation place if there are unfavourable light conditions.

```

---Main menu---
Code: "D"
> ▶ Device configuration
  ▶ Calibration
  ▶ Setpoint settings
  ▶ Temperature
  compensation
  ▶ Relay settings
  ▶ Analog outputs
  ▶ Device data
Language: English
    
```

```

Device configuration
> Disinfection      Free chlorine
Redox measurement  yes
pH measurement     yes
Contrast           40
Bus address        63
    
```

Use  or  to select the desired contrast.

Confirm with the ENTER  button.

Note:
The new contrast is displayed after confirmation.

10.4 Setting the bus address

Step 1: Log in to code level C or higher

Step 2: Select "Device configuration" in the menu

Step 3: The current bus address is displayed in "Bus address" and can be adjusted there

10.5 Fuse

Fuse 250V
400mA, slow-blow
type

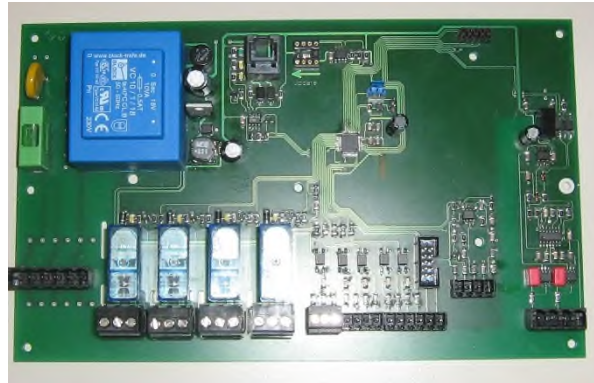

10.6 Liquid dosing agents for your PC DYNAMICS 4 system

You desire hygienically clean and crystal-clear water in order to feel good and relax in your pool?

Our system provides everything required for this purpose. To ensure a trouble-free operation of the system, it is also important that you use only treatment agents that are compatible with our devices, and where quality and effectiveness have been tested by dinotec.

Note:

Use only accessories and water care agents which have been tested and recommended by dinotec, and which are specially designed for this area of application and are subject to continuous quality controls.

The following treatment agents are available from your dinotec pool dealer.

Art. no.	Item name		
1060-120-00	dinochlorine liquid	35 kg	for disinfection
1060-122-00	dinochlorine liquid	22.5 kg	for disinfection
1060-290-00	dinominus liquid	40 kg	to reduce the pH level
1060-292-00	dinominus liquid	24 kg	to reduce the pH level
1060-295-00	dinoplus liquid	40 kg	to raise the pH level
1060-297-00	dinoplus liquid	27.5 kg	to raise the pH level
1060-383-00	dinofloc ULTRA liquid	35 kg	for turbidity removal
1060-299-00	dinofloc ULTRA liquid	22 kg	for turbidity removal

Note:

Do not use any organic chlorine compounds!

Warning:

The use of concentrated hydrochloric acid in the immediate vicinity of our equipment invalidates the guarantee!

Caution:

Keep the dinochlorine dosing agent in a cool and dry place. Keep out of direct sunlight.

Do not mix different dosing agents. Please observe the relevant information and safety instructions on the product labels.

11 Electrical connection/Terminal diagram – device model private

Attention:

Connect the device only to a 230V / 50Hz AC power plug!

Explanations:

NC: Normally Closed, output works as normally closed contact

NO: Normally Opened, output works as normally open contact

COM: Common, shared connection

From wire connector box N, L, PE: There are three 5-pin wire connector boxes connected in the unit for power distribution

Note:

The plugs can be removed for an easier installation of the connection cables outside the terminal box.

Exception: The double plug of the two cables for pH and redox.

Note:

A resistor with a value of 1.1 kohm is installed at the works for terminal 23-24 (water temperature sensor). When connecting the Pt1000, this resistor must be removed.

Note:

The container empty signal device must work as normally open contact.

Operating instructions Electrical connection/Terminal diagram – device model private

Attention:

The terminal diagram applies exclusively to the private device model. For the professional device model, see chapter 12.

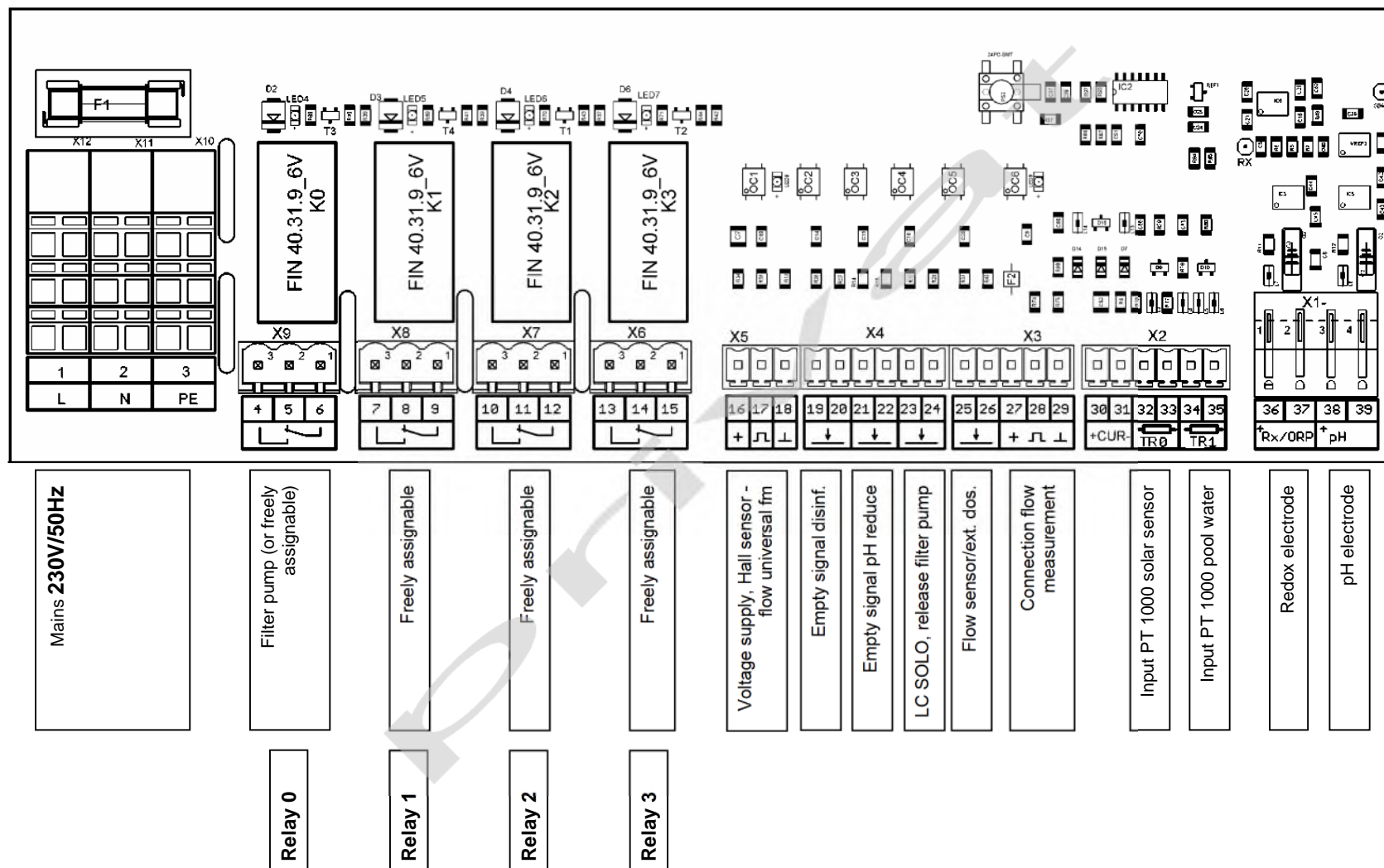

Operating instructions Electrical connection/Terminal diagram – device model private

Terminal markings:

No.	Terminal	Function
1	6x L	Power input 115V ±10% or 230V ±10% 50/60Hz (Automatic switching)
2	6x N	
3	6x PE	
4	NC	Relay REL0 – Filter pump 230V (with RC element) / freely assignable if no filter control is activated.
5	NO	
6	COM	
7	NC	Heating / solar (activated in case of filter control and heating/solar), otherwise: Relay REL1 – Disinfection, pH raise, pH reduce, heating control, solar control, collective alarm, flocculation, off
8	NO	
9	COM	
11	NC	Relay RED2 - Dosing chlorine, pH reduce, pH raise
2	NO	
13	COM	
3	NC	Relay RED3 - Dosing chlorine, pH reduce, pH raise, collective alarm
14	NO	
15	COM	
16	+24V	Voltage supply for Hall sensor Flow meter universal fm
17	Pulse	
18	GND	
19	↓	BIN1 – Empty signal chlorine
20		
21	↓	BIN1 – Empty signal pH reduce
22		
24		
25	↓	BIN 3 - Flow sensor for switching the system off (external dosing stop)
26		
27	+24V	Flow measuring cell
28	Pulse	
29	GND	
30	+CUR	Not assigned
31	-CUR	
32	TR0	-50 °C->+150°C temperature input PT1000 solar temperature
33		
34	TR1	0° ->50°C temperature input Pt 1000 sample water/pool water for sample water or heating control
35		
36	+	Measuring input redox (0-1 V) Range: -1V to +1V
37	RX/OPR	
38	+	Measuring input pH (0-14 pH) Range: -1V to +1V
39	pH	

12 Electrical connection/Terminal diagram – professional device model

Attention:

The terminal diagram applies exclusively to the professional device model. For the private device model, see chapter 11.

Connection chlorine gas controller, see page 76

Operating instructions Electrical connection/Terminal diagram – professional device model

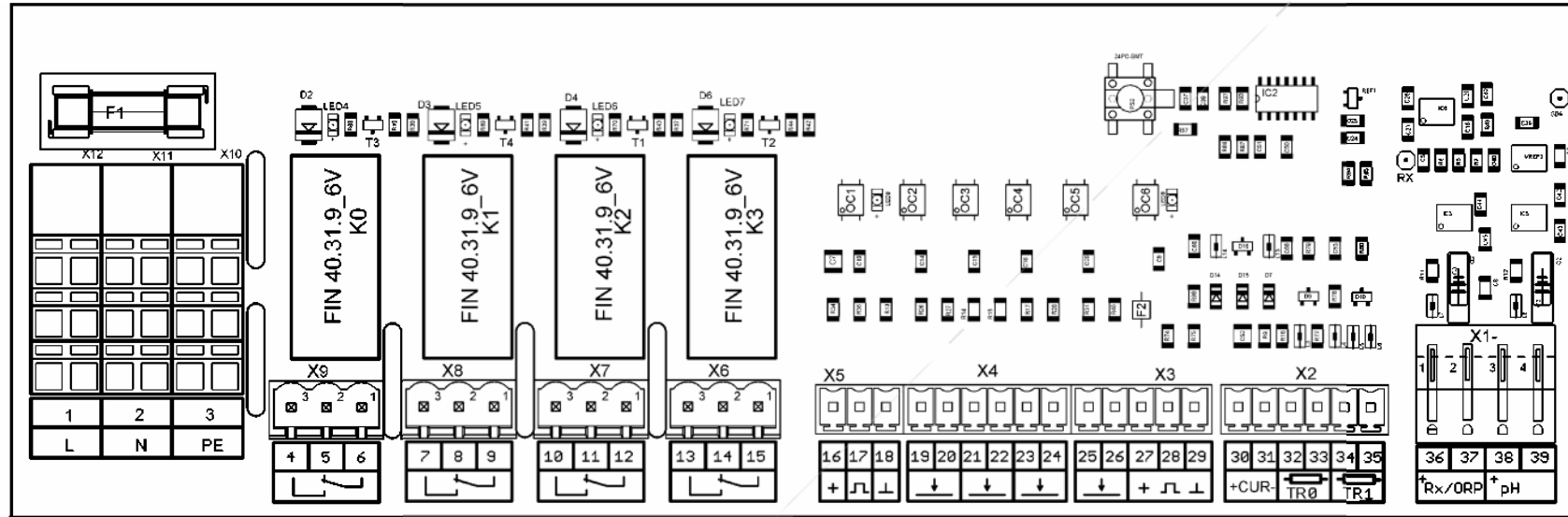

Mains 230V/50Hz

Disinfection raise

pH raise/reduce / Flocculation

pH raise/reduce /flocculation

Alarm relay
pH raise/reduce /flocculation

Sample water deficiency
Terminal 17-18 (NOC)

Empty warn. disinf.

Empty warn. pH reduce

Empty warn. pH raise

Dos. off
Ext.

Connection dimodos/TAB
flow measurement

Input feedback potentiometer
from chlorine gas regulator

Redox electrode

pH electrode





Relay 0

Relay 1

Relay 2

Relay 3

Terminal markings:

No.	Terminal	Cable colour	Function
1	6x L		Power input 230 ±10% Attention: Only connect 230V / 50Hz!
2	6x N		
3	6x PE		
4	NC		Relay REL0 - Dosing of disinfectant / Chlorine gas regulator "OPEN"
5	NO		
6	COM		
7	NC		Relay REL1 - Dosing pH raise / pH reduce / Chlorine gas regulator "CLOSED" (switchable)
8	NO		
9	COM		
11	NC		Relay REL2 - Dosing pH raise / pH reduce / Flocculation (switchable)
12	NO		
13	COM		
13	NC		Relay REL3 - Collective alarm / Dosing pH raise / pH reduce / Flocculation (switchable)
14	NO		
15	COM		
16	+24 V	Brown	Terminal 16 is only assigned in case of 'universal' measuring cell! Flow meter sample water (see below) Connect float switch to terminal 17-18
17	Pulse	green	
18	GND	White	
19			BIN0 (Empty warning input chlorine/Poolcare)
20			
21			BIN1 (Empty warning input pH reduce)
22			
23			BIN2 (Empty warning input pH raise)
24			
25			BIN 3 Input deactivation of dosing
27	+ 24V	Brown	Input dinodosTAB flow measurement +24V DC Pulse input Ground
28	Pulse	Green	
29	GND	White	
30	V0		Free
31	GND		Input feedback potentiometer from chlorine gas regulator

Operating instructions Electrical connection/Terminal diagram – professional device model

			(Potentiometer 1000 Ω, optionally 100 Ω)
32	TR0		
33			
34	TR1	Blue	
35		Black	
36	+ RX/ORP	Silver	Measuring input redox (0-1 V)
37		White	
38	+ pH	Silver	Measuring input pH (0 - 14 pH)
39		White	

12.1.1 Connection actuator for chlorine gas

Please observe that the actuator for chlorine gas is connected as follows:

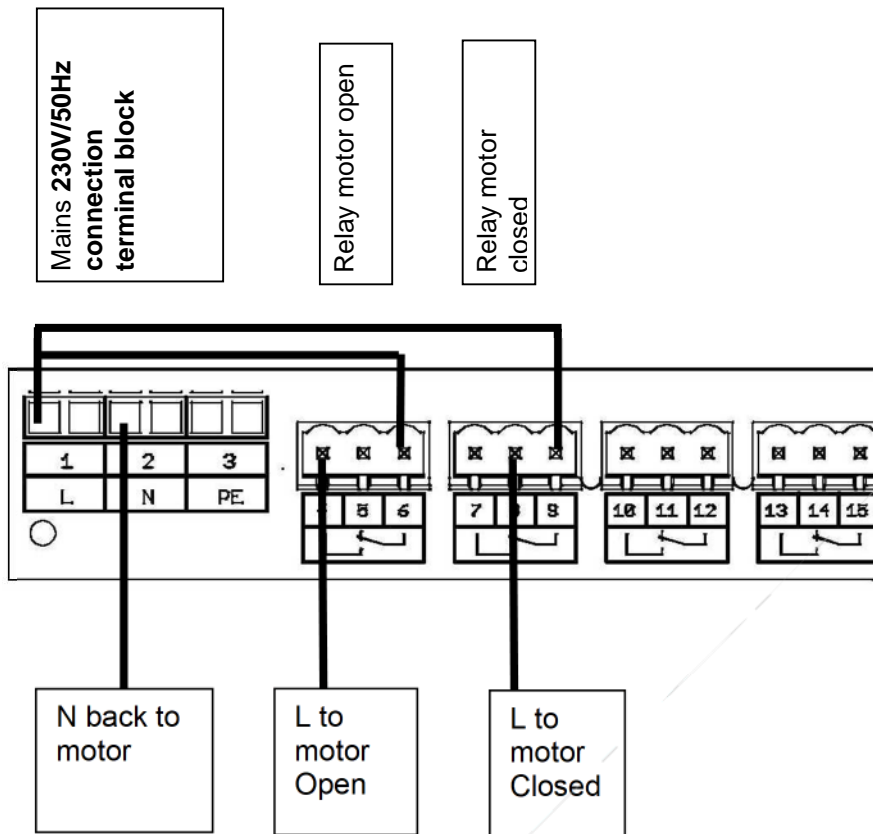

The following table indicates which relay is to be switched during the various actions of the motor controller:

Activity	Relay 0	Relay 1
Open	energised	energised
Closed	de-energised	de-energised
Stop	de-energised	energised

12.1.3 Terminal description potentiostatic measuring board

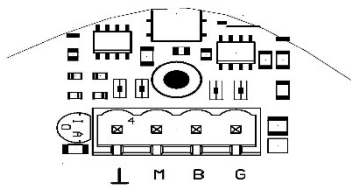

No.	Terminal	Cable colour	Function
50	-I		GND
51	M	transparent/ flex	Measuring electrode measuring input chlorine, chlorine dioxide, ozone
52	B	white	Reference electrode
53	G	red	Counter electrode

12.1.4 Terminal description analog output board

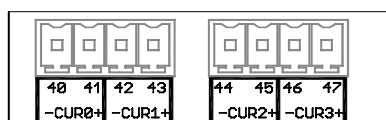

No.	Terminal	Name in menu	Default
40	- Cur0	Output 1	4-20 mA
41	+		
42	- Cur 1	Output 2	4-20 mA
43	+		
44	- Cur 2	Output 3	4-20 mA
45	+		
46 -	- Cur 3	Output 4	4-20 mA
47	+		

12.1.5 Connection of a diaphragm dosing pump via pulse frequency cable

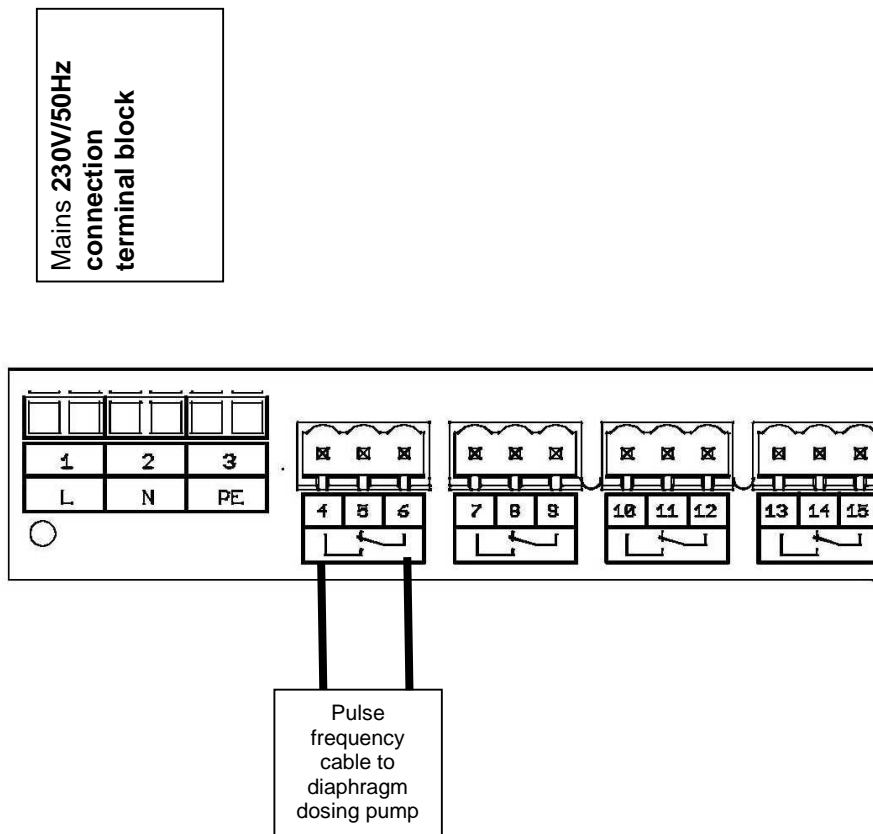

Select the relay that you want to connect the dosing pump to. Connect the pulse frequency cable to the relay (relay 1: connection 5/6) and plug the other end into the connection on the dosing pump. Go to the "Relay settings" menu and select the control mode "Pulse frequency", then enter the control frequency of the dosing pump.

12.1.6 Sample water monitoring via flow measurement

Connection Hall sensor

Hall sensor for flow measurement with sample water turbine (impeller) 0100-014-00.

Flow capacity: 410 pulses/liter

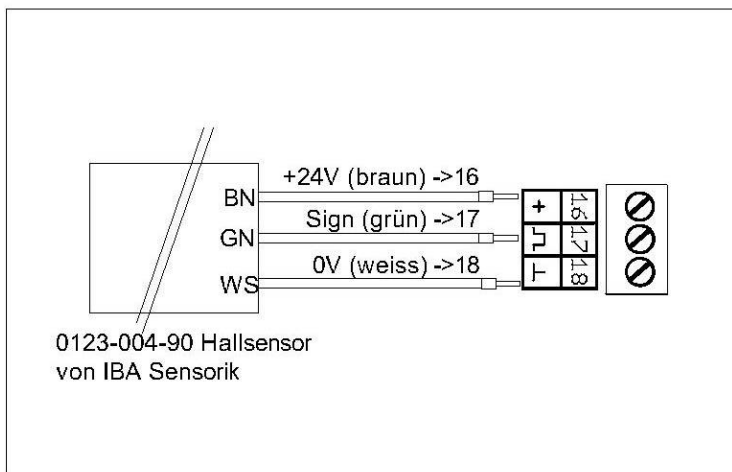

Pool fun can be so easy!



Simply enjoy the best water!

dinotec GmbH Philipp-Reis-Str. 28 D-61130 Nidderau
Tel.: +49(0)6187-413 79 -0 +49(0)6187-41379-90
Internet: www.dinotec.de; E-mail: mail@dinotec.de